

# DOCUMENTED BRIEFING

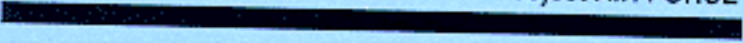


## *Proliferated Autonomous Weapons*

*An Example of Cooperative Behavior*

*David Frelinger, Joel Kvitky, William Stanley*

*Project AIR FORCE*



## PREFACE

The Air Force has significantly reduced the size of its combat air forces in response to changing national military objectives and declining budgets. Because of its smaller force structure, the Air Force now has fewer combat airplanes to replace on a steady-state basis, but the modernization funding burden remains high because of increasing development and procurement costs for these platforms. Further force structure reductions could lie ahead if acquisition funding falls short of levels needed to sustain the force.

Mission responsibilities of today, while different from those of the Cold War, are still very demanding, and will have to be accomplished with a smaller force structure and with fewer fiscal resources. Maintaining existing capabilities and meeting new challenges will be especially difficult in such a setting. A RAND Project AIR FORCE research project entitled "New Concepts for Ground Attack" has examined opportunities for maintaining or enhancing selected Air Force capabilities for ground attack by capitalizing on new technical approaches and operational concepts.

The third and final milestone briefing summarizing overall results was presented at the action officer level on 30 May 1997. Two additional briefings on 1 July 1997 to the project officer from the Office of Global Attack, Deputy for Forces, Director of Operational Requirements, USAF/XORF, provided more details about specific ground attack technologies and concepts. A briefing summarizing final project results was presented to the project sponsor, the United States Air Force Director of Operational Requirements (Hq USAF/XOR), on 8 September 1997.<sup>1</sup> It compared the survivability and weapon delivery efficiency of alternative attack concepts, examined how technology could influence the resources needed for ground attack, and assessed the potential utility of nonlethal technologies and weapon system concepts using cooperative behavior logic.

This documented briefing focuses on one element of the project research; it describes a proliferated weapon concept developed during the project that relies on a unique combination of modern communications and sensor technology, cooperative behavior logic

---

<sup>1</sup>A documented briefing of these results is in preparation.

inspired by the study of natural systems, and new robotics concepts based on parallel control architectures. Within the defense community, these results should be of interest to development planners, conventional airpower analysts and policymakers, and weapon designers. Outside the defense community, individuals following developments in the fields of artificial life and cooperative robotics may find this work of interest.

“New Concepts for Ground Attack” is part of Project AIR FORCE’s Force Modernization and Employment Program.

## **PROJECT AIR FORCE**

Project AIR FORCE, a division of RAND, is the Air Force federally funded research and development center (FFRDC) for studies and analyses. It provides the Air Force with independent analyses of policy alternatives affecting the development, employment, combat readiness, and support of current and future aerospace forces. Research is performed in three programs: Strategy and Doctrine; Force Modernization and Employment; and Resource Management and System Acquisition.

# CONTENTS

Preface.....	iii
Figures.....	vii
Summary .....	xi
Acknowledgments.....	xiii
Acronyms .....	xv
1. INTRODUCTION.....	1
2. THEORY .....	9
3. APPLICATIONS.....	23
4. TECHNOLOGY ASSESSMENT .....	59
5. CONCLUSIONS .....	70
Appendix: MADAM Model Description .....	75
Bibliography .....	79

# FIGURES

1.1.	Proliferated Autonomous Weapons: An Application of Cooperative Behavior.....	1
1.2.	Outline, Introduction.....	3
1.3.	Cooperative Systems Approach for Addressing Challenging Targets.....	4
1.4.	Targets Not Always Serviced Well Today.....	6
1.5.	Framework for Analysis.....	8
2.1.	Outline, Theory.....	9
2.2.	Theoretical Foundations.....	10
2.3.	Ethology, Artificial Life, and Cooperative Robotics: The Group as an Organism.....	11
2.4.	Emergent Behavior.....	14
2.5.	Example: Ant Foraging Behavior Rules.....	15
2.6.	Complex Behavior Emerges from a Simple Set of Rules: Simulation of Ant Foraging Behavior.....	17
2.7.	Implementation of a Swarming Algorithm: Classic vs. Parallel Control Architectures.....	19
2.8.	Implementation of a Swarming Algorithm: Subsumption Architecture for a Possible Munition.....	21
3.1.	Outline, Weapons and Targets.....	23
3.2.	Cooperative Behavior and Swarming.....	24
3.3.	Cooperative Behavior and Swarming (continued).....	25
3.4.	Against Fixed Targets Virtual Mission Planning Is an Attractive Characteristic.....	27
3.5.	Some Possible Weapon Configurations.....	29
3.6.	LOCAAS Configuration.....	31
3.7.	Proliferated and Dispersed Targets Were Selected for Evaluation.....	32
3.8.	Representation of Air Defense Target Arrays in Swarm Simulation.....	33
3.9.	Functional Representation of a Single Mobile Air Defense Target Cluster.....	34

3.10.	Outline, Effectiveness and Characteristics Assessment .....	35
3.11.	Critical Issues Examined.....	36
3.12.	Swarming Algorithms May Permit the Use of Lower-Capability Sensors.....	38
3.13.	Improved Communication Enhances Effectiveness More Than Sensor Field of Regard for Large Targets .....	39
3.14.	Systems Using Cooperative Behavior Logic Show Greater Robustness to Increases in Target Location Error .....	41
3.15.	Systems Using Communications and Cooperative Behavior Logic Can Exhibit Swarming Even at High Levels of Attrition .....	43
3.16.	Sensor and Communications Systems Characteristics Derived from Effectiveness Assessment.....	44
3.17.	Outline, Theater Applicability.....	46
3.18.	Attributes of Targets Most Suitable for Attack by Weapons Exhibiting Swarming Behavior .....	47
3.19.	Number of Targets for Which Swarming Behavior Offers Advantages .....	48
3.20.	Swarming Weapons Are Potentially Advantageous for a Significant Portion of an MTW Target Set.....	49
3.21.	Outline, Enhancing Existing Concepts.....	51
3.22.	Simple Communications Can Also Be Added to Existing Weapons to Boost Performance.....	52
3.23.	Damocles Operational Concept.....	53
3.24.	Target Designation Logic .....	55
3.25.	Communications Provide Greatly Enhanced Effectiveness .....	57
4.1.	Outline, Technology Assessment.....	59
4.2.	Critical Supporting Technologies for Proliferated Systems .....	60
4.3.	IR Communications System Block Diagram.....	61
4.4.	Observations About IR Communications Option.....	63
4.5.	Radio Frequency Communications Option .....	65
4.6.	LADAR Automatic Target Recognition.....	66
4.7.	Laser Radar Scanning Technology .....	67

4.8.	Improved Explosives, Case Designs, and Multimode Warheads.....	68
5.1.	Outline, Conclusions.....	70
5.2.	Conclusions Regarding Cooperative Weapon System Concept.....	71
5.3.	Possible Next Steps in Evolution of Weapons Using Cooperative Behavior.....	73

## SUMMARY

This exploratory research examines whether modern communications and sensors, advances in robotics architectures, and adaptations of analytical modeling of natural systems may permit the development of unique proliferated weapon concepts employing swarms of weapons. On the most fundamental level, the work seeks to examine whether application of the robotics architectures and the cooperative behavior exhibited by natural systems can in fact elicit desired weapon behaviors. Second, the research examines whether there are technologies available to support the concept. The research is intended to demonstrate the potential feasibility of the concept, not to develop a definitive set of weapon system requirements or to argue for the adoption of this concept to the exclusion of existing concepts.

The weapons use LADARs (LASER Detection And Ranging) with limited fields of regard and automatic target recognition algorithms. Simple communications of limited range across the swarm of weapons in the radio frequency (RF) or infrared (IR) spectrum compensate for the limited fields of regard of the LADARs. Weapons within communications range keep aware of what the other weapons are seeing and the actions they are taking. A simple rule set of discrete behaviors adapted from modeling of natural systems (e.g., flocking of birds, food foraging by ants) governs the operation of the weapons as they search for, home on, and attack targets.

As currently envisioned, the weapons would be relatively simple platforms, with the smallest effective payload (to reduce size and cost) and with a minimal set of onboard detection devices to sense the environment and each other. One form of the weapon might be similar in size and configuration to the Air Force's developmental High Leverage Munition-Anti-Materiel Submunition (HLM-AMS), one configuration of which is called the Low Cost Autonomous Attack System (LOCAAS), which weighs approximately 100 pounds in its turbojet-powered version and has a variety of carriage possibilities. Alternative larger configurations might be utilized for more demanding targets. Our research has envisioned delivery by aircraft platforms, although in principle they could be delivered by surface-to-surface missiles as well.

In the concept explored here, individual weapons may be less capable than conventional weapons under development today, but through



communications across the swarm of weapons, the group exhibits behaviors and capabilities that can exceed those demonstrated by more conventional systems that do not employ communications between weapons. The weapon concept offers a range of potential benefits, including possible relaxed sensor performance requirements, robustness to increases in target location errors, and adaptivity to attrition and poor target characterization.

This research (1) develops the rationale for investigating cooperative behavior between Proliferated Autonomous WeapoNs, or PRAWNs, equipped with near-term automatic target recognition systems, (2) develops the conceptual basis for implementing cooperative behavior (in biology and robotics), (3) identifies weapon applications for systems embodying these concepts and assesses their effectiveness, (4) examines technical approaches for meeting the communications and sensor needs of the weapons, and (5) makes suggestions for maturing the weapon concept.

## ACKNOWLEDGMENTS

Barry Wilson of RAND implemented a cooperative weapon behavior logic in the *Swarm* computer simulation to assist in evaluating the effectiveness of proliferated autonomous weapons. Gail Halverson of RAND adapted and applied the MADAM weapon engagement simulation model to assist in assessing the potential of adding communications to developmental weapon concepts. Eiichi Kamiya reviewed the document.

## ACRONYMS

AAA	Anti-aircraft artillery
AFV	Armored fighting vehicle
AI	Artificial intelligence
AJ	Anti-Jam
AMS	Anti-materiel submunition
AMSAA	Army Materiel Systems Analysis Agency
ATR	Automatic target recognition
BAT	Brilliant Anti-armor Technology
C3	Command, Control, Communications
C4I	Command, Control, Communications, Computers, Intelligence
COTS	Commercial Off-The-Shelf
DARPA	Defense Advanced Research Projects Agency
DSP	Digital Signal Processor
ELINT	Electronic Intelligence
EM	Electromagnetic
FFRDC	Federally Funded Research & Development Center
FOR	Field of Regard
FPA	Focal Plane Array
GAMES	Guided Artillery Munitions Effectiveness Simulation
GPS	Global Positioning System
HARM	High-speed Anti-Radiation Missile
HLM	High Leverage Munition
IEEE	Institute of Electrical and Electronic Engineers

ID	Identification
INS	Inertial Navigation System
IR	Infrared
IMU	Inertial measurement unit
ISR	Intelligence, Surveillance, Reconnaissance
LADAR	LASER Detection and Ranging
L/D	Lift-to-drag ratio
LED	Light Emitting Diode
LOCAAS	Low Cost Autonomous Attack System
LPI	Low Probability of Intercept
MADAM	Model to Assess Damage to Armor with Munitions
MALD	Miniature Air-Launched Decoy
MIT	Massachusetts Institute of Technology
MLSD	Maximum Likelihood Sequence Detector
MLRS	Multiple Launch Rocket System
MRC	Major Regional Conflict
MTW	Major Theater War
NASA	National Aeronautics and Space Administration
NSF	National Science Foundation
OOK	On-Off Keying
P3I	Pre-planned product improvement
PAF	Project Air Force
POL	Petroleum Oil Lubricants
PPM	Pulse Position Modulation
PRAWN	Proliferated Autonomous Weapon
R&D	Research & Development
RF	Radio Frequency
SAM	Surface-to-Air Missile

SSM	Surface-to-Surface Missile
TLE	Target Location Error
TMD	Tactical Munitions Dispenser
UAV	Unmanned Aerial Vehicle
UPC	Unit Procurement Cost
WLAN	Wireless Local Area Network

# 1. INTRODUCTION



**Figure 1.1—Proliferated Autonomous Weapons: An Application of Cooperative Behavior**

This documented briefing summarizes results from one aspect of a Project AIR FORCE study conducted for the Director of Operational Requirements. The project examined opportunities for maintaining or enhancing selected Air Force capabilities in the ground attack mission area by capitalizing on new technical approaches and operational concepts.

The aspect of the research documented here explores how advances in robotics and cooperative behavior logic coupled with on-board communications and sensors could enable the development of new air-to-ground proliferated weapon concepts. The robustness, adaptivity, and effectiveness of these weapons could open up new

avenues for ground attack. We refer to these weapons by the acronym PRAWNs, Proliferated Autonomous WeapoNs.<sup>1</sup>

---

<sup>1</sup>Proliferated autonomous weapons do not inherently have to communicate. However, in our concept the communications system on board the weapons allows them to share information. The weapons use the information to make decisions based on *cooperative behavior* logic. Weapons following the logic developed in our research characteristically exhibit *swarming behavior*.



**Introduction**

**Theory**

**Weapon applications**

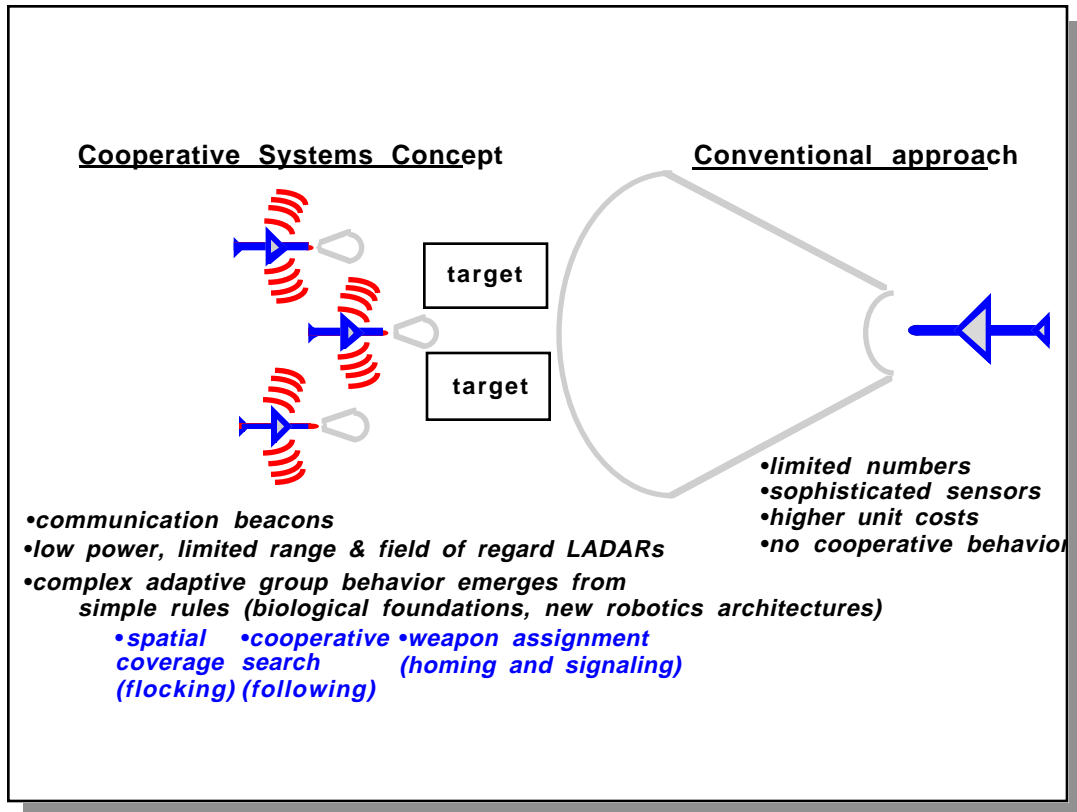
**Technology assessment**

**Conclusions**

**Figure 1.2—Outline, Introduction**

The briefing describes research that (1) develops the rationale for investigating cooperative behavior between proliferated autonomous weapons equipped with near-term automatic target recognition systems, (2) develops the conceptual basis for implementing cooperative behavior (in biology and robotics), (3) identifies weapon applications for systems embodying these concepts and assesses their effectiveness, (4) examines technical approaches for meeting the communications and sensor needs of the weapons, and (5) makes suggestions for maturing the weapon concept.





**Figure 1.3—Cooperative Systems Approach for Addressing Challenging Targets**

The cooperative systems approach, as envisioned here, relies on modern communications, advances in robotics architectures, and adaptation of analytical modeling of natural systems to develop a unique proliferated weapon concept. In this concept, the individual weapons may be less capable than conventional weapons under development today, but through communications across the swarm of weapons, the group exhibits behaviors and capabilities that can exceed those demonstrated by more conventional systems that would generally not employ communications between weapons.

The concept features LADARs with limited fields of regard and automatic target recognition algorithms.<sup>2</sup> Simple communications of

<sup>2</sup>A LADAR is a scanning laser that uses returns from coherent light waves to develop position information and images of scanned targets. The acronym stands for LASER Detection And Ranging.

limited range across the swarm of vehicles in the radio frequency (RF) or infrared (IR) spectrum compensate for the limited field of regard of the individual weapons. Weapons within communications range keep aware of what the other weapons are seeing and the actions they are taking. A simple rule set of discrete behaviors adapted from modeling of natural systems (e.g., flocking of birds, food foraging by ants) governs the operation of the weapons as they search for, home on, and attack targets.

The ability to use cooperative behavior offers a range of potential benefits, including relaxed sensor performance needs (e.g., smaller fields of regard), robustness to increases in target location errors, and adaptivity to attrition and poor target characterization. We will quantify some of these benefits in succeeding figures.

**Mobile / relocatable air defense units a serious problem for the USAF**

- **Advanced long-range SAMs (SA-10C / SA-12)**
- **Tactical SAMs**
- **AAA and short range air defenses**

**Target sets containing large numbers of identifiable aimpoints burden intelligence and mission planning**

- **Airfield complexes with many exposed elements**
- **Munition storage facilities**
- **Communications nodes / teleports**

**Figure 1.4—Targets Not Always Serviced Well Today**

Why should the Air Force be interested in weapons that use cooperative behavior? Our work suggests such weapons have the potential for significantly improving the Air Force's ability to service important classes of high-value targets. Moreover, the manner in which they operate may reduce some intelligence and mission planning burdens.

There are several benefits of the swarming behavior that results from the cooperative behavior logic used by these weapons. (1) The use of group behaviors significantly changes the calculus of weapon designers by allowing for the use of individually less-capable weapons. (2) Because the group self-organizes, the mission planning requirements (either pre-mission or onboard) are significantly relaxed, since the importance of an individual weapon going astray is much lower. (3) From an implementation standpoint, the system is built on readily verifiable stimuli-response pairs that make constructing

adaptive algorithms much simpler than in systems employing models of cognition.

The use of civil technologies also offers the possibility of further reducing the costs of developing the weapons since it may be possible to relax individual system reliability and performance relative to an approach using smaller numbers of platforms.<sup>3</sup> Of the civil technologies, low-cost spread-spectrum communications, both commercial micro-processors and digital signal processors, and algorithms developed for adaptive behavior in nonmilitary settings seem to offer a possible source of technologies appropriate for future generations of weapons.

---

<sup>3</sup>Civil in this context refers to technologies sponsored by entities other than the U.S. Department of Defense, such as NASA or the National Science Foundation or the commercial sector.

## **Objective**

- Explore the potential of innovative cooperative air-to-ground weapon system concepts that integrate advances in ethology (science of animal behavior), robotics, and modern civil and military technology

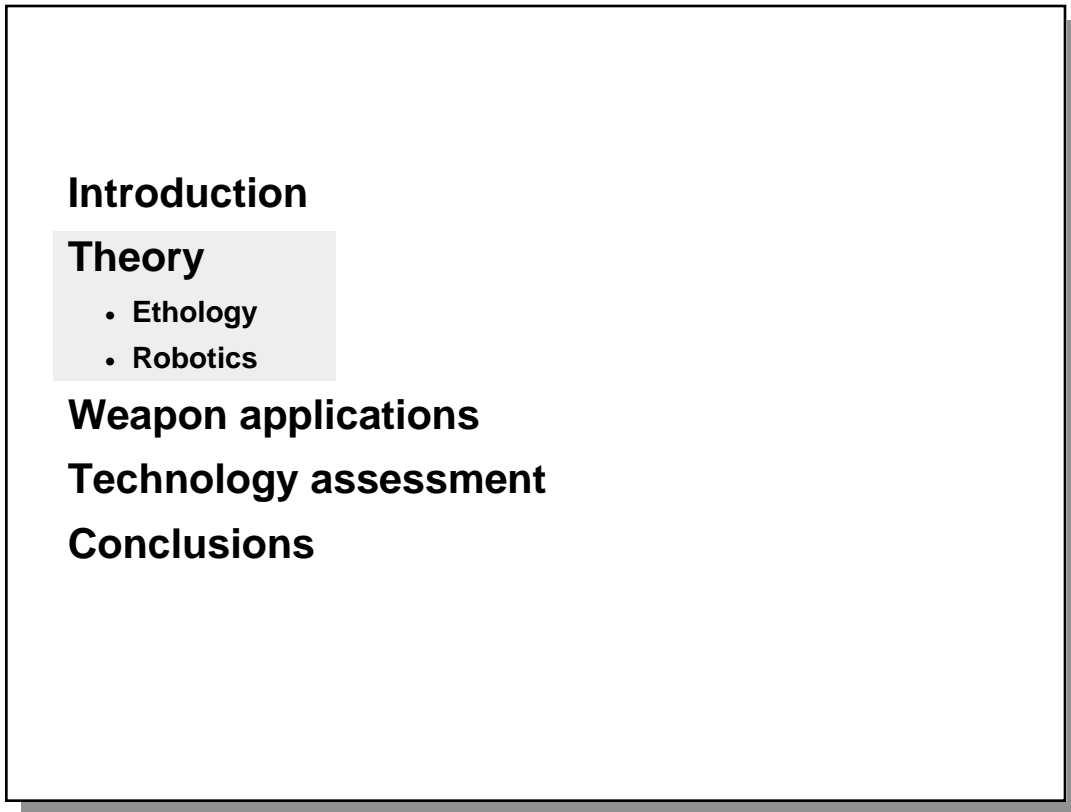
## **Approach**

- Establish theoretical foundations
- Develop a simulation to test rule sets governing weapon behavior
- Evaluate weapon effectiveness against representative targets
- Assess technologies needed by the weapons
- Suggest approaches for advancing the weapon concept

**Figure 1.5—Framework for Analysis**

Our objective was to take advantage of advances in several different technologies to develop and evaluate unique cooperative weapon system concepts. We first established the theoretical foundations for the cooperative behavior and developed several simulations of increasing complexity to test and refine the rules governing weapon behavior. We used those simulations to evaluate the effectiveness of the weapon concepts and to define in broad terms desired technical characteristics. We then assessed technical approaches for developing the weapons and identified opportunities for maturing the weapon concepts through preplanned product improvement (P3I) initiatives in existing programs.

## 2. THEORY



**Figure 2.1—Outline, Theory**

This weapon concept relies on technologies in both the civil and military sector. We will describe how attributes of ethology (the science of animal behavior) and robotics developed in the civil sector can be applied to the weapon concept.

- **Ethology (Science of Animal Behavior)**
  - Aggregation
  - Foraging
  - Homing
  - Emergent Behavior
  - Flocking
  - Following
- **Robotics**
  - Classic vs. Subsumption Architecture
  - Homogeneous vs. Heterogeneous Cooperation

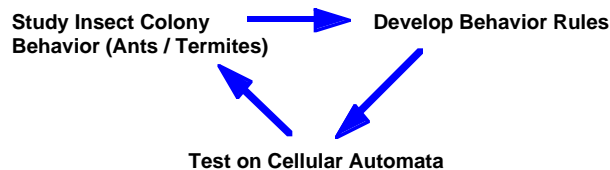
*The key is combining the lessons from both communities to the task of constructing a collective of individual weapons to perform a complex task with minimal information under a broad range of conditions*

**Figure 2.2—Theoretical Foundations**

Scientists studying animal behavior have identified and analytically modeled a number of behaviors of natural organisms that have parallels to the things that weapons have to do to search for, acquire, and attack targets. Similarly, scientists in the field of robotics have developed alternative architectures for controlling the behavior of individual robots and the collective behavior of multiple robots working as a group that might also find parallels in proliferated weapon concepts. Developments from these two communities provide a foundation for developing innovative weapon concepts.

The real key to our approach is combining the lessons from both communities to construct individual munitions, and to allow for the organization of those weapons to perform a variety of complex tasks under a broad range of conditions.

- Artificial life studies provided breakthroughs in understanding decentralized, self-organizing animal behavior
- Sources of emergent behavior of natural systems—Ilya Prigogine
- Mathematical characterization of emergent behavior—Simon Goss and Jean-Louis Denoubourg, Free University of Brussels



- Rule-based simulation of bird flocking behavior—Craig Reynolds' 3-D artificial birds or “boids”
- Rule based simulation of bat sequences in *Batman Returns*—Andy Kopra
- Simulation of virtual cooperative robots for possible planetary exploration application—Rodney Brooks, MIT

**Figure 2.3—Ethology, Artificial Life, and Cooperative Robotics: The Group as an Organism**

Recently, studies that independently sought the origin of ordered behavior in colonies of primitive plants or animals, in physical systems under non-equilibrium conditions, and in cellular automata or artificial life, have coalesced into an emerging universal science of self-ordered systems.<sup>4</sup> The seminal ideas of this branch of science can be traced to the work of Nobel-Prize winning physicist Ilya Prigogine.<sup>5</sup> During the 1970s, he showed that “emergent behavior” can arise through self-organization among large numbers of ruled-based entities. Soon thereafter, Simon Goss and Jean-Louis Denoubourg at the Free University of Brussels analyzed mathematically the seemingly

<sup>4</sup>Ellen Thro, *Artificial Life Explorer's Kit*, Sams Publishing, Carmel, IN, 1993; Stephen Levy, *Artificial Life: The Quest for a New Creation*, Pantheon, New York, 1992.

<sup>5</sup>Ilya Prigogine and Isabelle Stengers, *Order Out of Chaos: Man's New Dialogue with Nature*, Bantam Books, New York, 1984.



intelligent construction of nests by termites and the aggregation of slime molds.

The group behavior of termites illustrates many of the phenomena of interest for the PRAWN weapon concept, in particular the generation of complex, coherent behavior among entities obeying simple rules, having sufficient numbers, and communicating in a primitive fashion. In the case of termites, the construction of their nest results from two competitive processes, the random transport and dropping of lumps of earth, and their attraction toward a high concentration of hormones, with which the termites impregnate the lumps. The resultant process is autocatalytic since a greater concentration of earth leads to a steeper hormone gradient in the neighborhood, which attracts more insects to drop their loads, etc. The rate and effectiveness of the aggregation process improve with the density of insects, i.e., there is some critical density below which aggregation does not occur. If “pillars” do appear, their initial development can be traced to a higher density nucleus of earth produced by a random fluctuation in the localized insect population. Our research suggests that the efficacy of adaptive behavior in PRAWNs also depends on the exchange of information and on attaining a critical threshold number of weapons.

A key element in the development of PRAWNs is the specification of rule sets that produce the desired behavior. Research that provides the requisite insights is being pursued in the fields of cellular automata and cooperative robotics. In the 1980s, researchers into cellular automata (which rose to fame through the “Game of Life”) discovered that the source of complex social behaviors that have long puzzled ethologists could be explained by artificial life analogues. One such early study by Craig Reynolds showed that a succinct set of rules would suffice to reproduce the salient features of flocking that are observed in nature, including the ability to move coherently without a leader, to avoid obstacles, and to regroup after dispersal to avoid a predator. Reynolds developed a three-dimensional simulation of his artificially living birds, which he named “boids.” A more graphically sophisticated version of Reynolds’ boids was used by Andy Kopra to generate the bat sequences in the movie *Batman Returns*. We developed an inverted form of the flocking rules to spread swarm weapons apart to efficiently cover target regions.

More recently, Rodney Brooks of MIT’s Mobile Robotic Group has demonstrated the principles of self-organization using virtual cooperative robots, with an eye to possible applications in planetary

exploration.<sup>6</sup> A rock collecting mission was simulated in which the virtual robots explored by means of a random walk, returning to the main base by following an acoustic gradient. When the robots found the desired rock types using their automatic rock recognition systems, they dropped tags that attracted other robots to the rock-rich areas, much as hormones or pheromones are used by insects to attract their brethren. In our weapon simulations, this following behavior improves the adaptability of PRAWN weapons and increases the number of weapons striking targets.

---

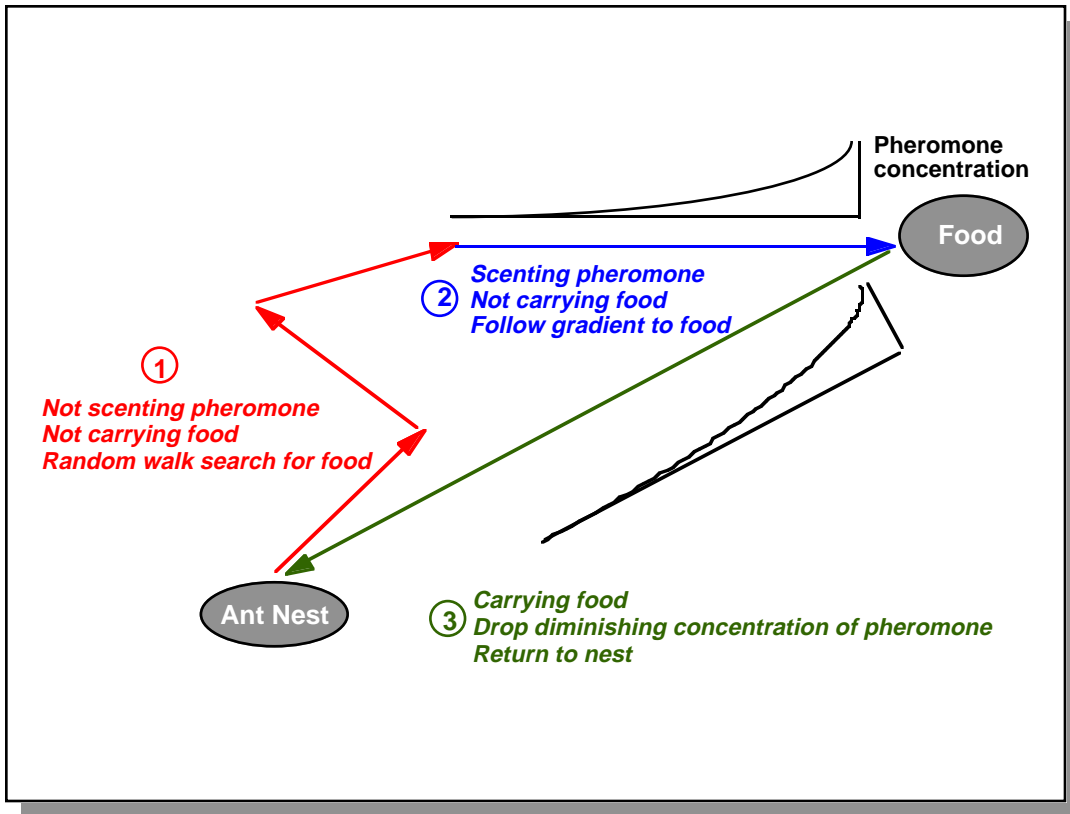
<sup>6</sup>Rodney Brooks, "New Approaches to Robotics," *Science*, Sept. 13, 1991, p. 1227.

**Complex, adaptive group behavior that emerges from proliferated, rule-based, “bottom-up” activity**

- **No centralized planning function**
- **No abstract world model**
- **Appears “intelligent”, but is not**

**Figure 2.4—Emergent Behavior**

The complex adaptive group behavior that emerges in the aforementioned examples, while appearing indicative of intelligence and centralized planning, is in fact derived from a finite set of relatively simple rules. We can illustrate this by stating the principal rules governing the behavior of artificial ants that can be applied to illustrate their behavior in foraging for food.



**Figure 2.5—Example: Ant Foraging Behavior Rules**

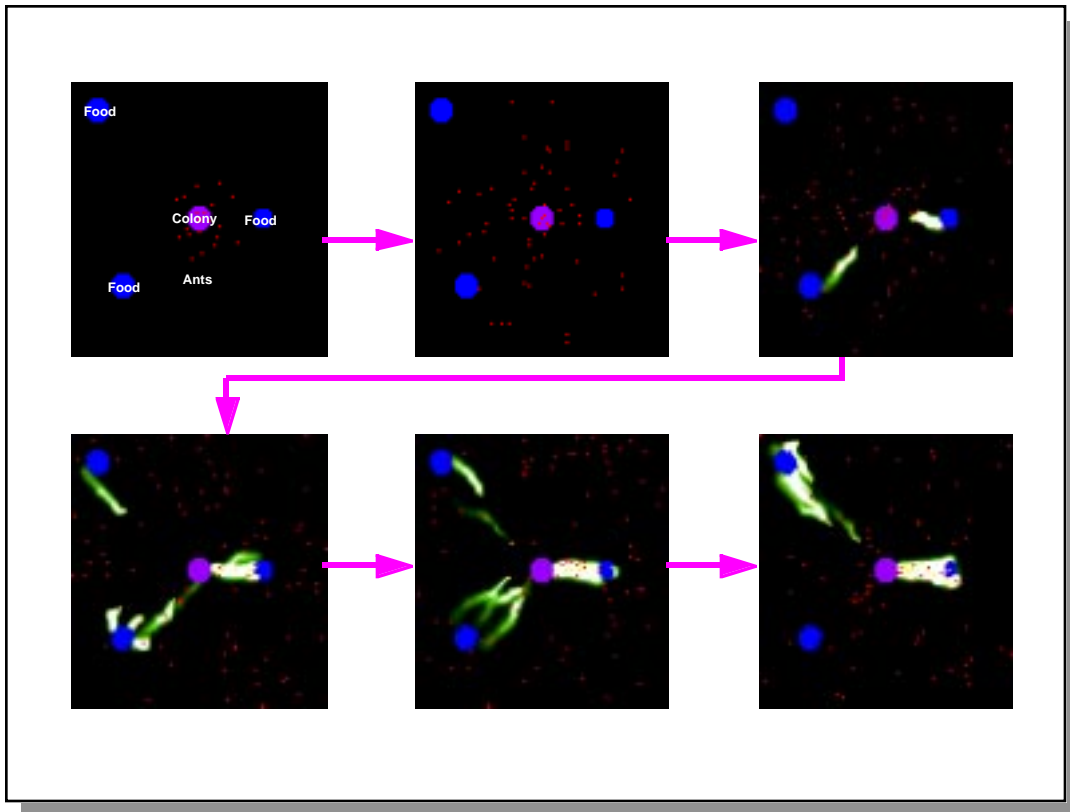
The principal rules governing the behavior of artificial ants are shown above. Additionally, the ant's pheromone is subject to the rule that it diffuses and evaporates uniformly over time.<sup>7</sup>

Studies of artificial ants have become the centerpiece of the research into the relationship between simple-individual and complex-collective behaviors. The aspect of interest in the design of swarming weapons is the use of recruitment strategies to implement effective foraging. This involves the use of visual and chemical cues in ants, but these can be translated into electromagnetic (EM) signals for the weapons application. Evidently, pheromones constitute narrow band signals, of which the closest EM relative is probably a beacon, or transponder. The important element is that the presence of a target, determined locally by short-range sensing and automatic target recognition, is communicated to a larger group of players which do

<sup>7</sup>Pheromone is a chemical substance ants secrete.

not have the target within their limited field-of-view or range. These are then entrained into the target-attacking activity.

Ants employ what is called *mass recruitment*. The ants lay down chemical trails when food is discovered and carried back to the nest. The amount of pheromone dispensed decreases as the nest is approached, with the result that a density gradient is established indicating the direction towards the food. The more ants involved in harvesting the food source, the more chemical is deposited, and hence the higher the probability of recruiting additional ants. Since the chemical trail evaporates over time, the attractiveness of the trail diminishes once the food source is exhausted.

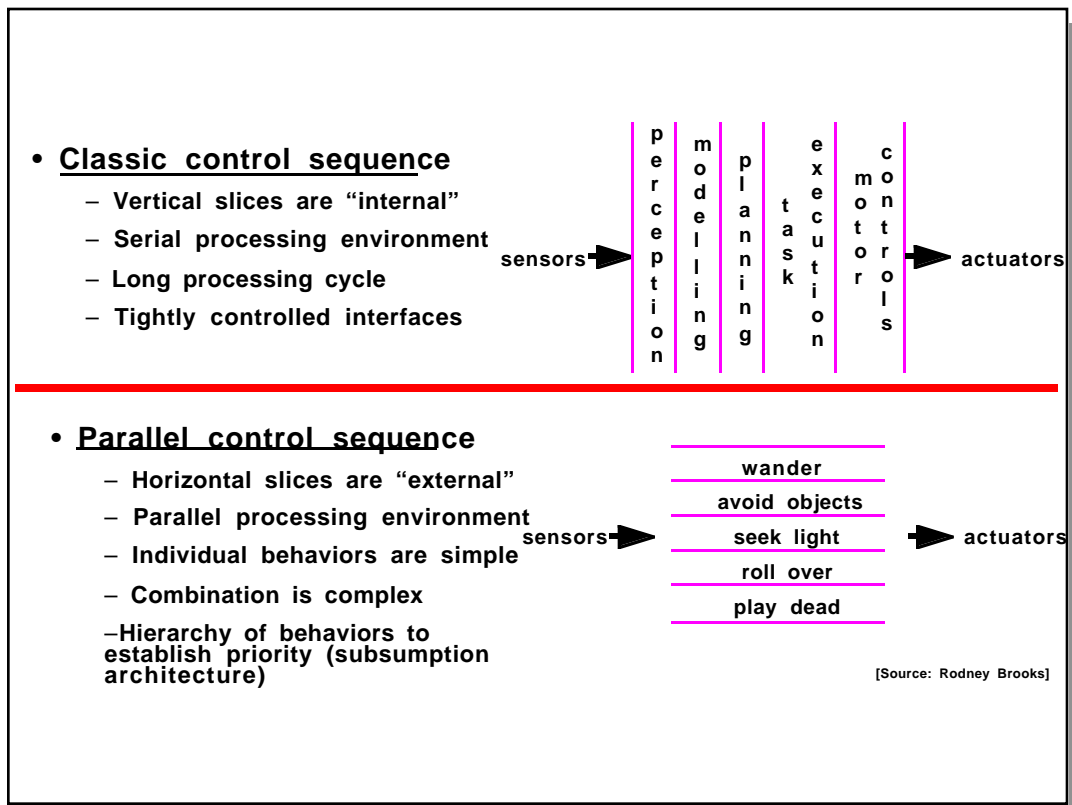


**Figure 2.6—Complex Behavior Emerges from a Simple Set of Rules:  
Simulation of Ant Foraging Behavior**

We applied a computer code called *Star Logo*, developed by researchers at the Massachusetts Institute of Technology (MIT), to observe the complex behavior that emerged from the simple set of rules we just introduced.<sup>8</sup> The six panels show progressively how the ants in the colony at the center of the screen fan out randomly to forage for food. The chemical trails begin to develop and are reinforced as the ants collect food from the rightmost and lower food sources. Ultimately, as the lower food source is exhausted, the chemical markers to it begin to evaporate, and activity is focused on the remaining food sources. The group as a whole exhibits rather sophisticated foraging behavior by following a very limited set of simple rules.

<sup>8</sup>Mitchel Resnick, *Turtles, Termites, and Traffic Jams: Explorations in Massively Parallel Microworlds*, MIT Press, Cambridge, Massachusetts, 1994.

A parallel control architecture is adopted to implement the rule-based behavior to yield the responsiveness needed for a weapon application.



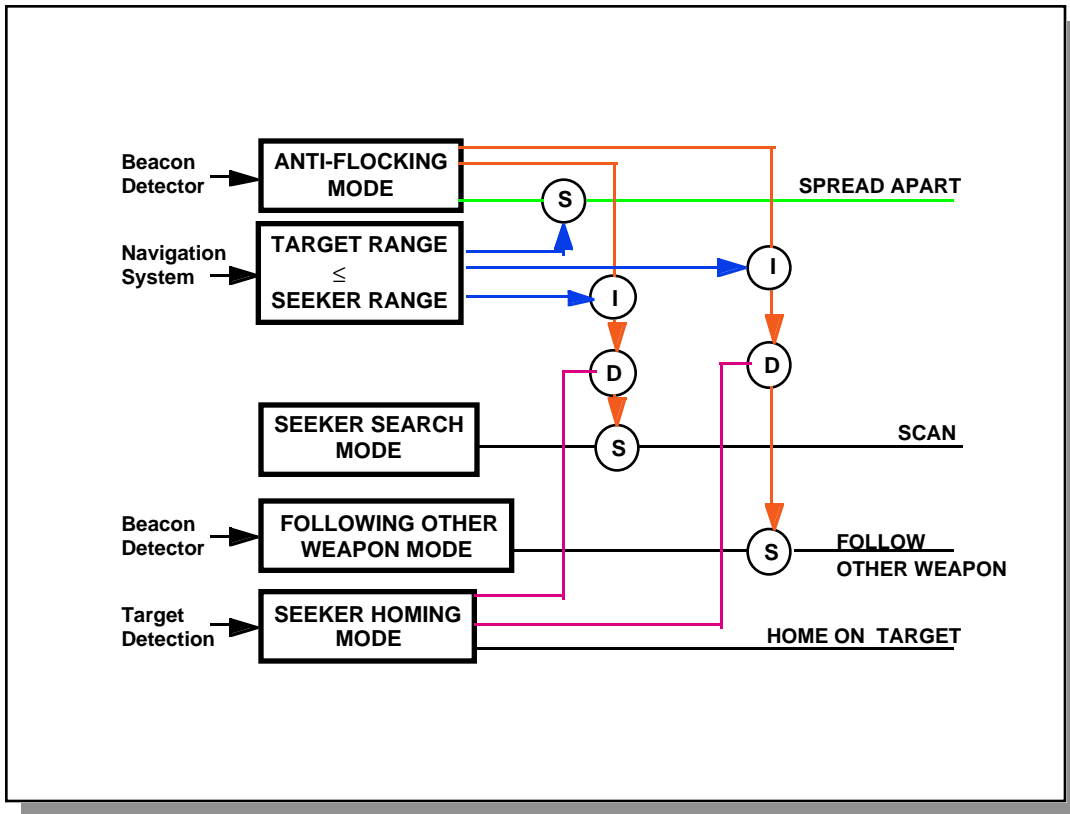
**Figure 2.7—Implementation of a Swarming Algorithm: Classic vs. Parallel Control Architectures**

Until recently, the world of robotic intelligence was dominated by the artificial intelligence (AI) paradigm. The AI robot has a centralized memory, pre-loaded with information about various kinds of objects, its goals, and how to execute key behaviors such as locomotion or avoidance. It has a centralized processor in which it updates and retains its picture of the world. Operationally, the AI robot gathers sensory data (e.g., scanning the room it occupies), develops a model of the world (e.g., where all the objects in the room are located), and then proceeds to plan how it will achieve its goal (e.g., walking forward while avoiding an obstacle). Only at this point does the robot begin to act, executing commands that control motor activities. This control sequence is serial, requiring that each internal process be completed before the next one commences. Consequently, the end-to-end processing cycle is long in relation to the demands of a changing real-time environment. Moreover, the interfaces between the “vertical



slices” in the process are complex; all the logical branches, which culminate in the full spectrum of behavioral options, need to be supported in each slice.

In the last decade, Rodney Brooks and Anita Flynn of MIT’s AI Laboratory have been building robots based on parallel architectures. The underlying ideas of this approach are closely related to artificial life, insofar as the robot’s complex behavior *emerges* from the interaction of simple rules that operate within each “horizontal slice.” The horizontal slices correspond to observable behaviors, which are processed continuously, and in parallel, but only one behavior is actually expressed at a time. The decision as to which behavior in the hierarchy takes precedence is a function of the subsumption architecture (explained in the next figure), which obviates the need to exercise centralized control.



**Figure 2.8—Implementation of a Swarming Algorithm: Subsumption Architecture for a Possible Munition**

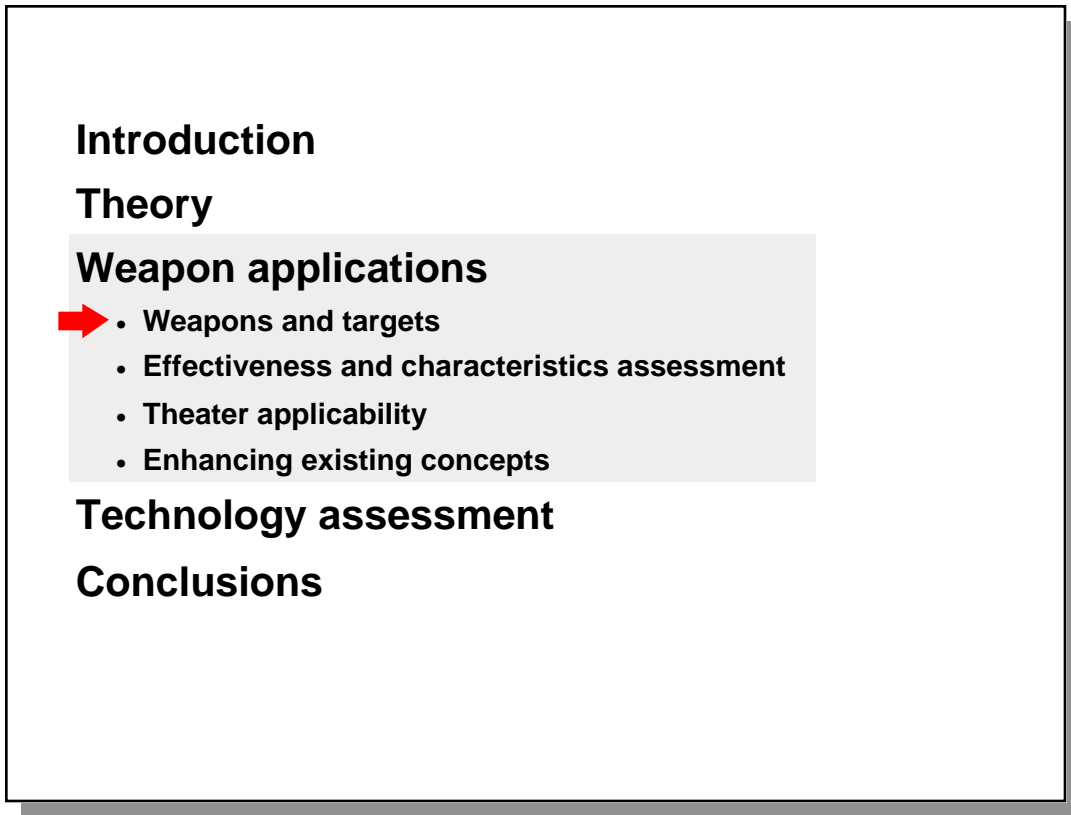
This diagram illustrates a candidate subsumption architecture for a swarm weapon. Each box corresponds to a behavior (anti-flocking, etc.) occupying a horizontal slice, alluded to in the previous figure. The processors allocated to each behavior are continually cranking (in parallel) based on the sensory inputs shown to the left. However, the behaviors are implemented only if they are allowed under the interactive subsumptive logic depicted to the right of the boxes. The outputs from the boxes are directed to actuators (e.g., “home on target”), and/or to sidetaps that influence the control of other behaviors. As we describe next, the priorities for the behaviors are adjudicated at the logical nodes in the diagram, and the priority assigned to one behavioral action may subsume another.

There are three logical processes—suppression (S), inhibition (I), and default (D)—that govern the control of input or output wires. Suppression and inhibition are similar in that the flow through the wire

is not affected when the sidetap is “off,” but the flow is disrupted when the sidetap is “on.” With default, the sidetap preempts the signal on the wire when that signal is “off,” but the sidetap is ignored when the signal on the wire is “on.”

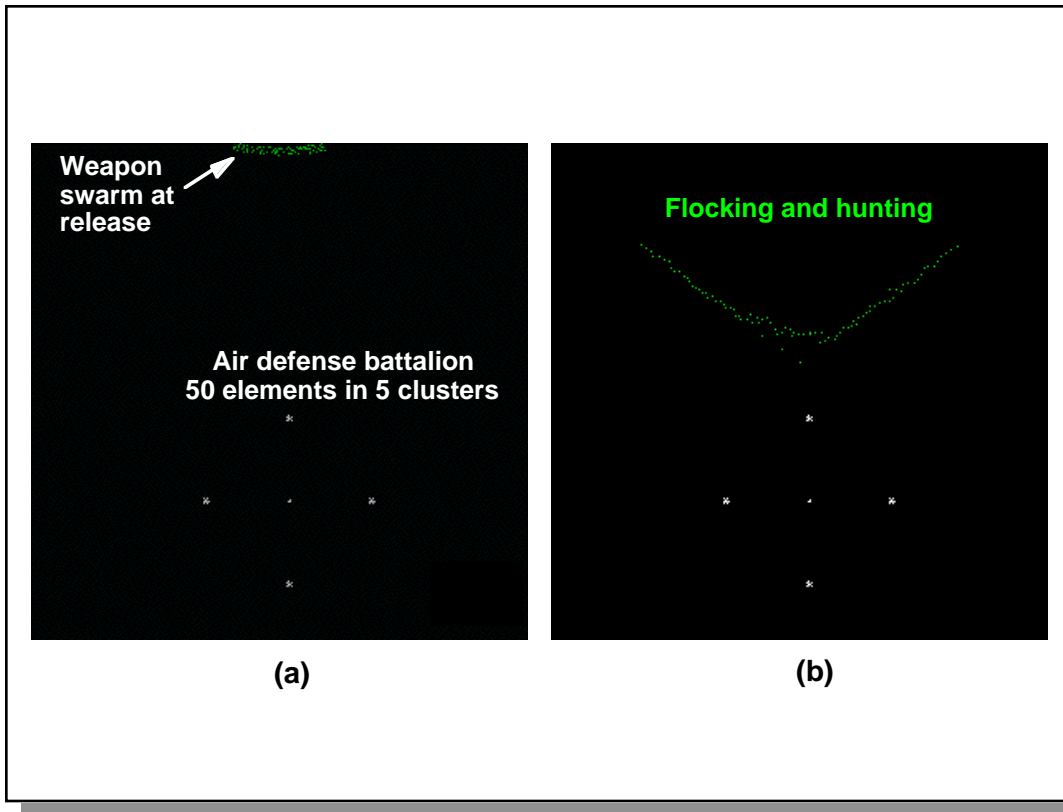
To see how the logic operates, we step through the “follow other” behavior. This behavior is activated when a weapon beacon is detected, but subject to the dictates of a very complex suppression sidetap. If the seeker homing mode is active, it preempts the default node, resulting in suppression of the following mode no matter what else is happening. If the seeker mode is not active, the following mode is suppressed by the operation of the anti-flocking mode, unless the target range decreases to less than the seeker range, at which point the inhibition caused by anti-flocking is itself turned off. The result is that following behavior is allowed, and one observes that the anti-flocking is also suppressed.

### 3. APPLICATIONS



**Figure 3.1—Outline, Weapons and Targets**

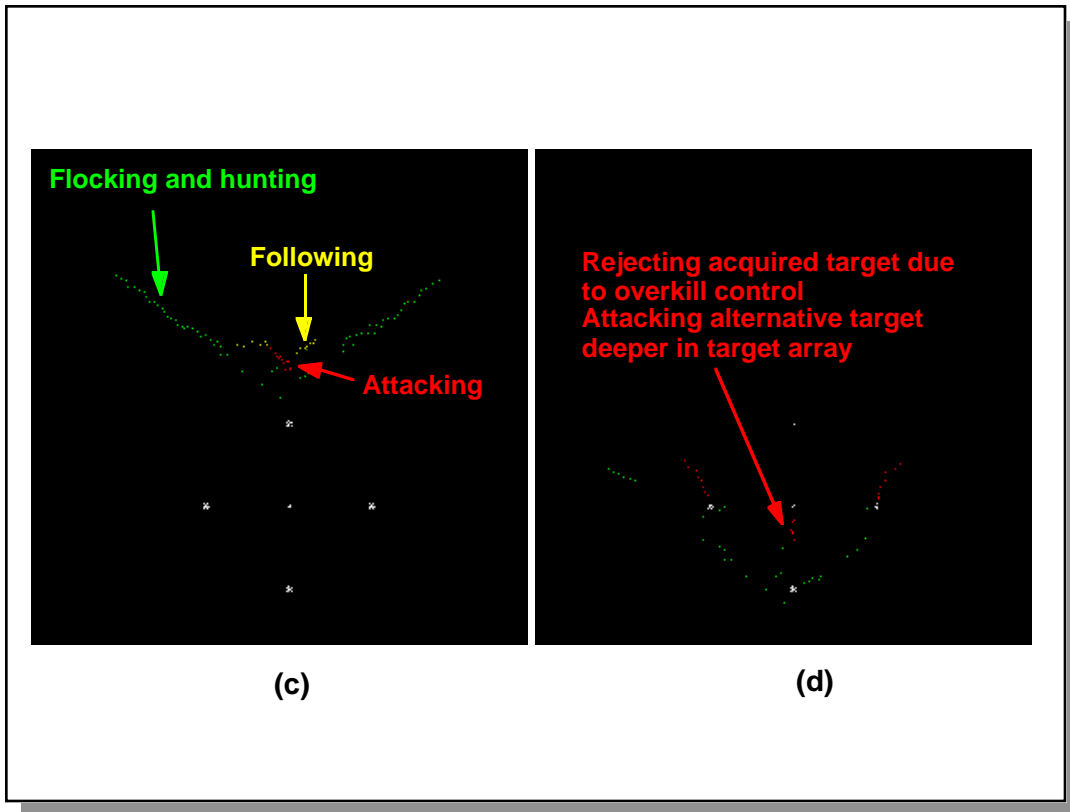
In applying the theoretical concepts to a weapon application, we considered the behaviors weapons would have to exhibit to find and destroy targets, postulated possible weapon configurations, and identified the targets they might go against.



**Figure 3.2—Cooperative Behavior and Swarming**

Before assessing capabilities of weapons using cooperative behavior, we will illustrate the sequence of behaviors the weapons use to engage an air defense battalion in 5 clusters with 10 target elements in each cluster (shown in white in the figure). Subsequent figures will describe in more detail both the simulation used to develop these results and the target.

The behaviors exhibited by the weapons in these frames are all in contention with one another, but only one is dominant at any moment in time. Panel (a) shows the weapons at release, before they have spread out. The weapons first use a flocking behavior to spread out, shown as the green “V” formation in panel (b). When they cross a designated threshold, they turn on their sensors and begin to hunt for targets.



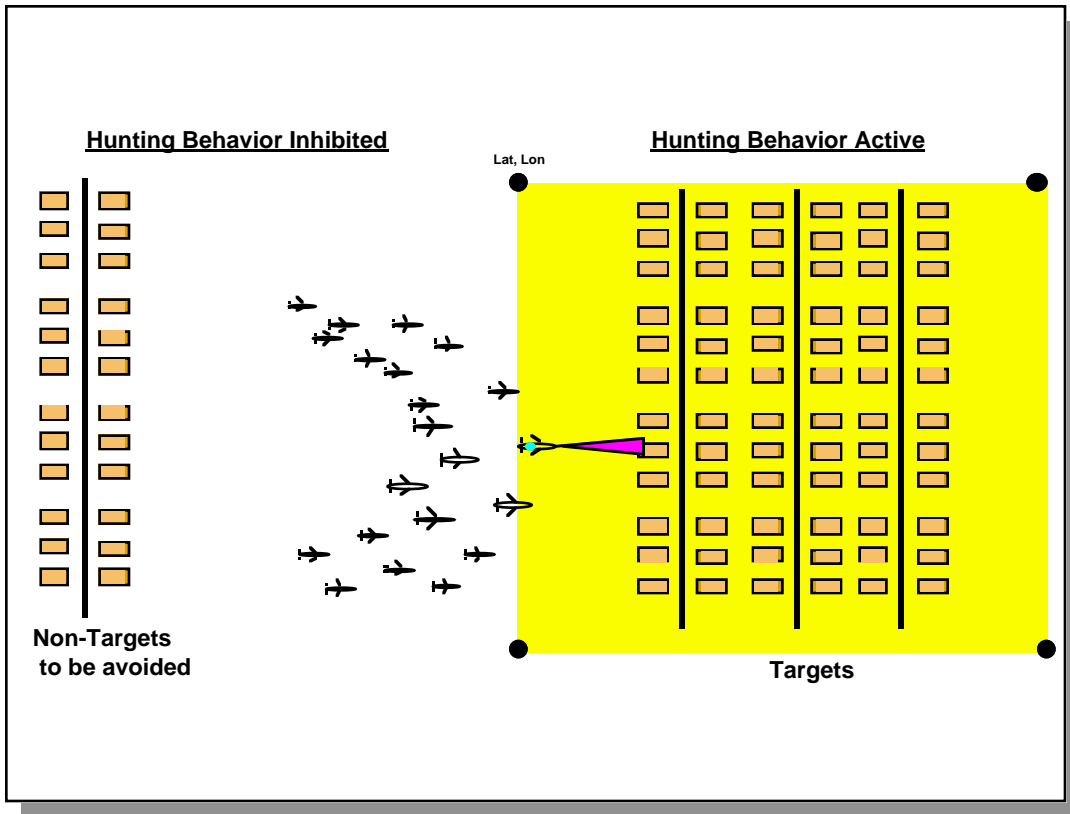
**Figure 3.3—Cooperative Behavior and Swarming (continued)**

Panel (c) shows multiple behaviors. Weapons shown in red have found targets, are homing on them, and are committed to the attack phase. Through communications, other weapons shown in yellow become aware of the targets, and if they meet certain proximity requirements, they begin to follow the weapons that are homing on targets. Weapons shown in green do not meet these proximity requirements and continue their flocking and hunting behavior to find other targets.

Panel (d) skips ahead. As attacks occur, coordinates of the targets being attacked are broadcast.<sup>9</sup> Consequently, weapons have knowledge of how many weapons have been committed to a given target. Simple rules prevent an excessive number of weapons from being expended on a single target. Once attack requirements have been met for a given target, other weapons reject that target and proceed to search for and attack other targets, in this case targets deeper in the

<sup>9</sup>Target elements shown in white are removed from the figure as they are destroyed.

array. Because this is a proliferated weapon concept, the viability of the concept does not depend on each individual weapon making “perfect” judgments of the tactical situation.



**Figure 3.4—Against Fixed Targets, Virtual Mission Planning Is an Attractive Characteristic**

Group “intelligence” can act as an antidote to escalating demands for complex and time-consuming mission planning for a variety of situations.<sup>10</sup> Mission planning can be accomplished as an emergent behavior, rather than as an outcome of top-down decisions, thereby offering the adaptability of manned systems while obviating the physical or virtual presence of human decisionmakers in the target area. Certain areas, perhaps those having noncombatants, could be excluded from attack a priori (see above), while other regions could be defined as eligible for attack when targets meeting automatic target

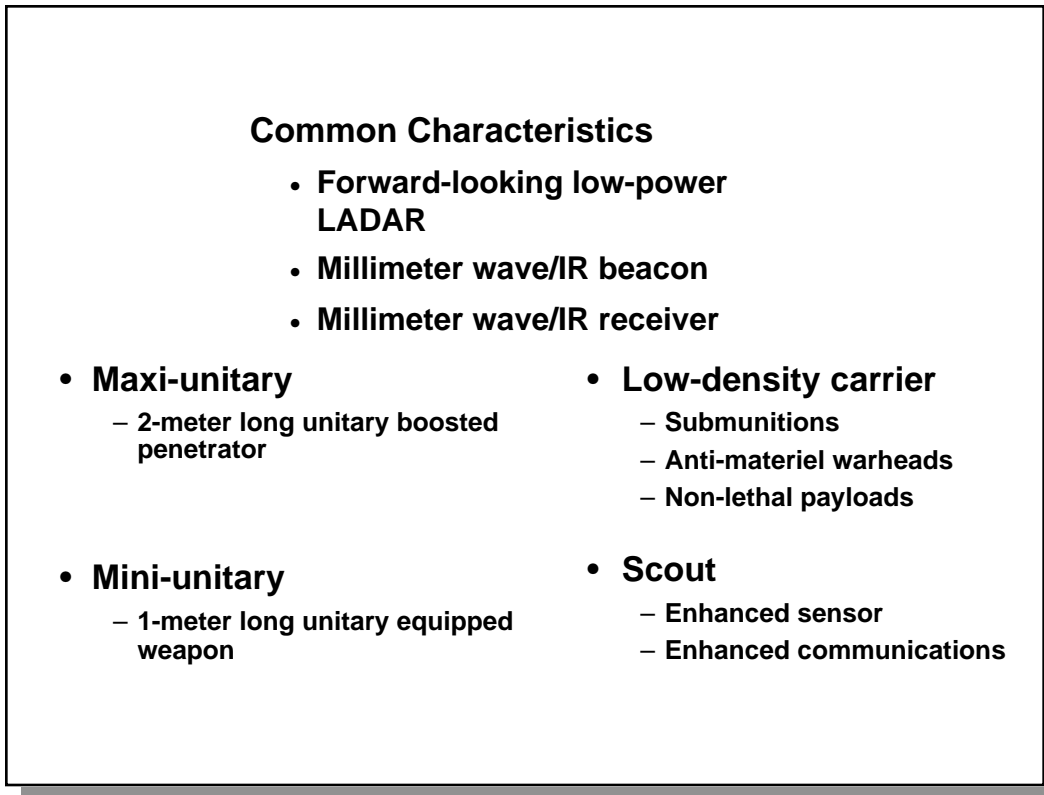
<sup>10</sup>There are still roles for traditional mission planning functions such as determining if weather conditions might allow for effective utilization of the weapons, as well as threat avoidance and coordination between launching platforms. For proliferated concepts addressed in this briefing, the latter issues are probably not very important, since many of the threats to the penetrating members of the swarm are in fact the intended targets for the group.



recognition criteria are identified, but without having to predefine each target in advance.

For those conditions in which no specific interaction is required at a particular time, or by a specific weapon, detailed mission planning may be avoided. For a field commander, this could eliminate some of the traditional planning burdens associated with automated weapons, though at the expense of losing fine-grained control of the individual munitions.

Recognizing that every situation will not meet the set of conditions needed for swarming weapons, we will later assess the fraction of targets in a major regional contingency that might be amenable to attack by weapons exhibiting such behavior.



**Figure 3.5—Some Possible Weapon Configurations**

As currently envisioned, the PRAWN vehicles would be relatively simple platforms with the smallest effective payload (to reduce size and cost), and with a minimal set of onboard detection devices to sense the environment and each other. One form of the weapon might be similar in size and configuration to the Air Force’s developmental High Leverage Munition–Anti-Materiel Submunition (HLM-AMS), one concept of which is called Low Cost Autonomous Attack System (LOCAAS), which weighs approximately 100 pounds in its turbojet-powered version and has a variety of carriage possibilities.<sup>11</sup> Our PRAWN research has similarly envisioned air delivery, although in principle they could be delivered by surface-to-surface missiles as well.

<sup>11</sup>Major Dave Jacques, *Low Cost Autonomous Attack System, LOCAAS*, Wright Laboratory, Armament Directorate, 1997; Michael Tower, *Powered Low Cost Autonomous Attack System (LOCAAS)*, Lockheed Martin Vought Systems, August 1996.

Communications among PRAWNs would be very simple, probably consisting of IR or millimeter-wave beacons that were limited to short ranges by atmospheric absorption (to minimize exploitation). Platforms with different payloads might be deployed if this improved the overall lethality of the swarm of weapons. This is in keeping with the biological paradigm of heterogeneous insect colonies, in which one commonly finds specialized members, e.g., soldier ants and worker bees.

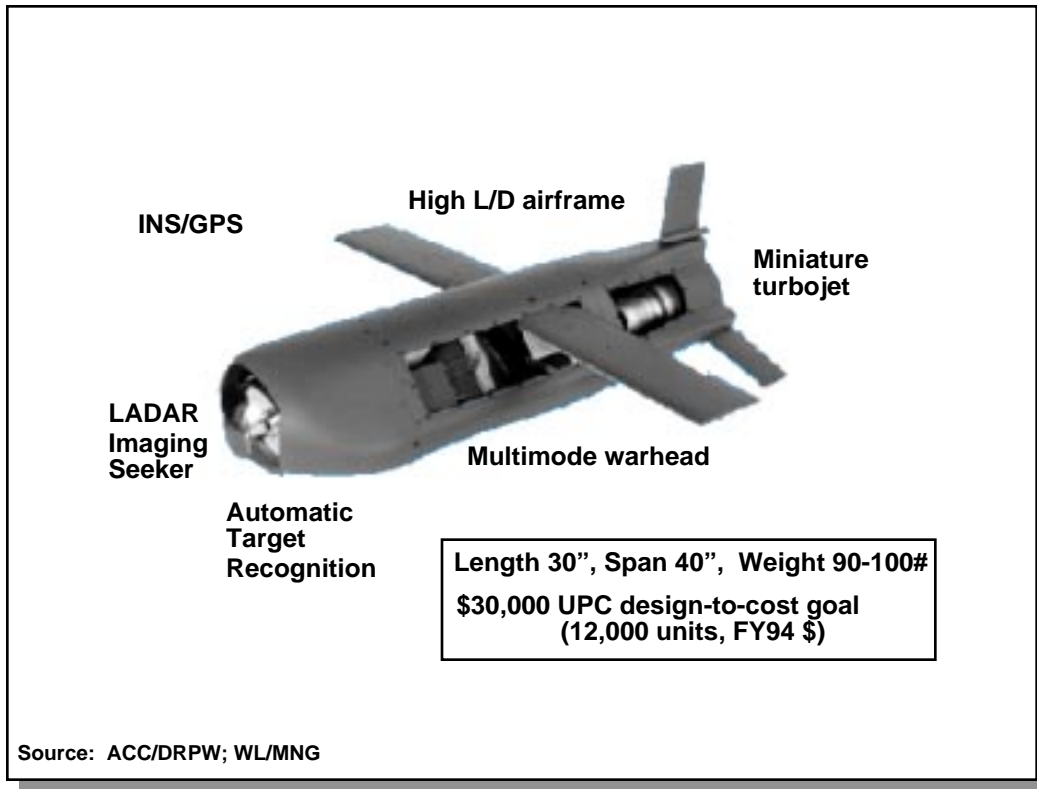
We have not done a detailed assessment of aerodynamic and propulsion requirements; hence, we cannot state definitively whether propulsion is a necessity. If it is, current low-cost engine concepts such as the TJ-50 being considered for the LOCAAS weapon and the MALD decoy can probably do the job at an engine unit cost well under \$10,000.<sup>12</sup>

Four notional weapon configurations are shown above. They include a pair of systems equipped with unitary warheads, a submunition/anti-materiel/nonlethal payload system, and a scout vehicle. The unitary systems might use small smart bomb technologies, along with boosted penetrator technologies that allow for attacks against hardened elements. In the case of the maxi-unitary, a 2-meter penetrator is hypothesized. The mini-unitary might use later generation explosives to shrink the warhead while retaining effectiveness. The low-density carrier might use a variety of payloads to accomplish its tasks, and correspondingly different shapes and end-game behaviors.<sup>13</sup> Finally, the scout vehicle might be used for reactive missions requiring group adaptability to threats, and/or specialized linkages that might allow for better overall performance.

---

<sup>12</sup>“Miniature Jet Engines Spawn Multiple Applications,” *Jane’s International Defense Review*, April 1996, pp. 15, 16.

<sup>13</sup>This configuration could be very similar to the LOCAAS weapon concept, with the addition of a communications system and cooperative behavior logic.



**Figure 3.6—LOCAAS Configuration**

This figure illustrates a powered LOCAAS with some of the essential elements of the configuration. A “low-density” PRAWN might share a similar configuration, with the addition of communications, cooperative behavior logic, and a possible relaxation in LADAR requirements. The multimode warhead could detonate as a stretching rod for hard armor penetration, an aerostable slug for increased standoff, or as fragments for a soft target kill. With such a remotely detonated warhead, the vehicle does not have to fly into the target.

### **Challenging targets for the Air Force**

- Relocatable air defense sites
  - Battalions
  - Companies
- Vehicles in columns

### **Some common characteristics of air defense and vehicular targets**

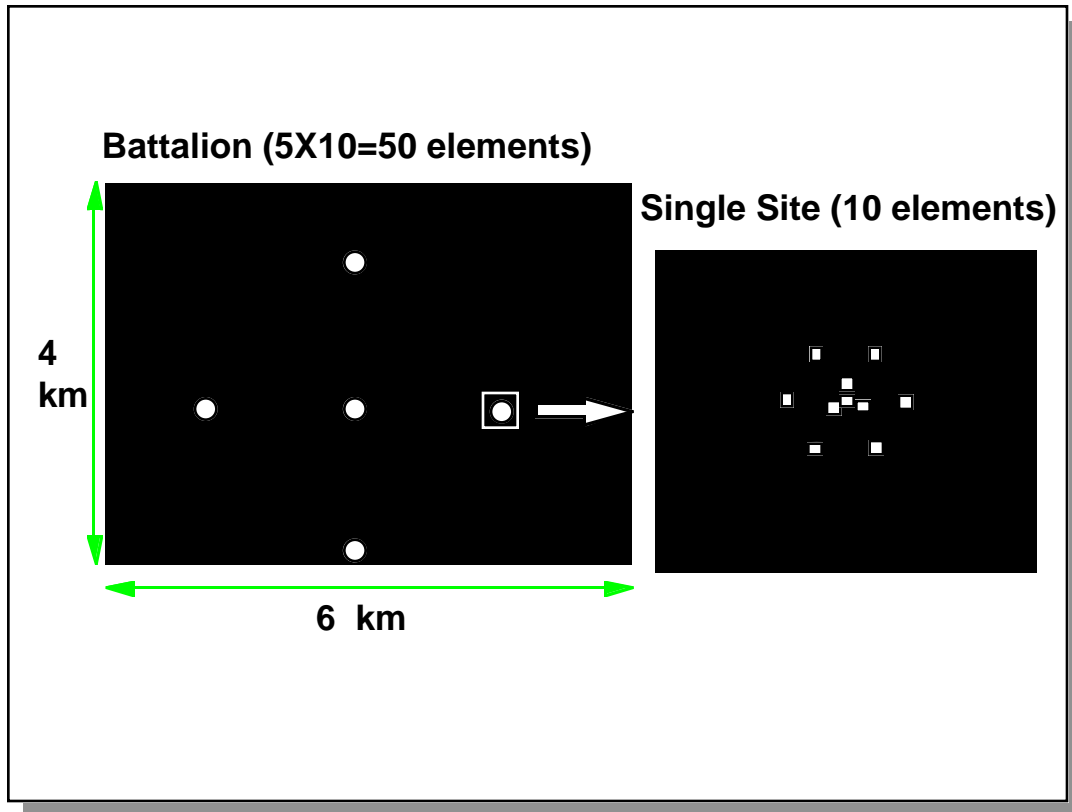
- Non-uniform distribution of target elements
- Large possible area of operation
- Significant uncertainty in target location

**Lessons from exemplar targets apply to many other target types**

**Figure 3.7—Proliferated and Dispersed Targets Were Selected for Evaluation**

We next develop effectiveness results for an air defense target, noting that several of its attributes would apply to other target types. These represent high-value targets for the Air Force today and are often difficult to attack with current operational concepts and weapons.

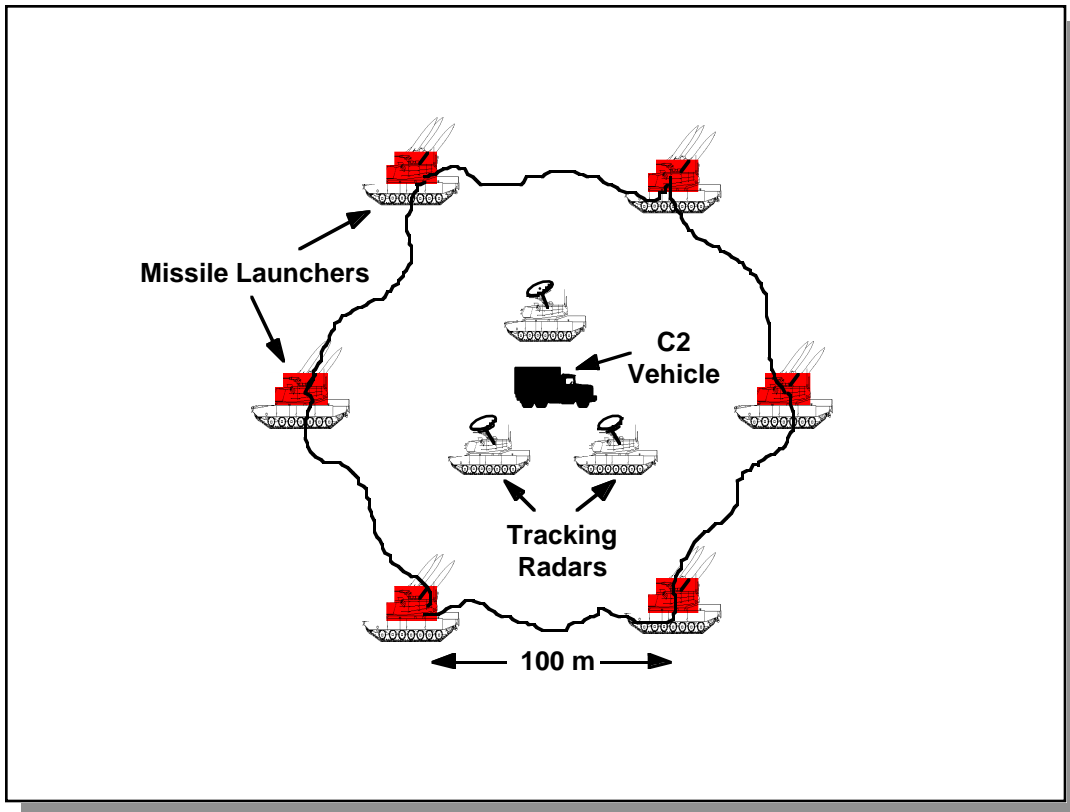
Subsequently, we will look across a full spectrum of major theater war (MTW) targets to assess the general applicability of swarming weapons.



**Figure 3.8—Representation of Air Defense Target Arrays in Swarm Simulation**

The air defense target array analyzed has five “clumps” of targets, with ten elements within each clump. These clumps are fairly widely spaced, and consequently, it would be difficult even for individual weapons having wide field of regard sensors to effectively detect the breadth of targets in such an array. Moreover, if the target is detected by means of electronic intelligence, the geometry of the battalion as a whole and the individual sites could be poorly characterized and the target location error could be a comparatively large fraction of the overall extent of the target.

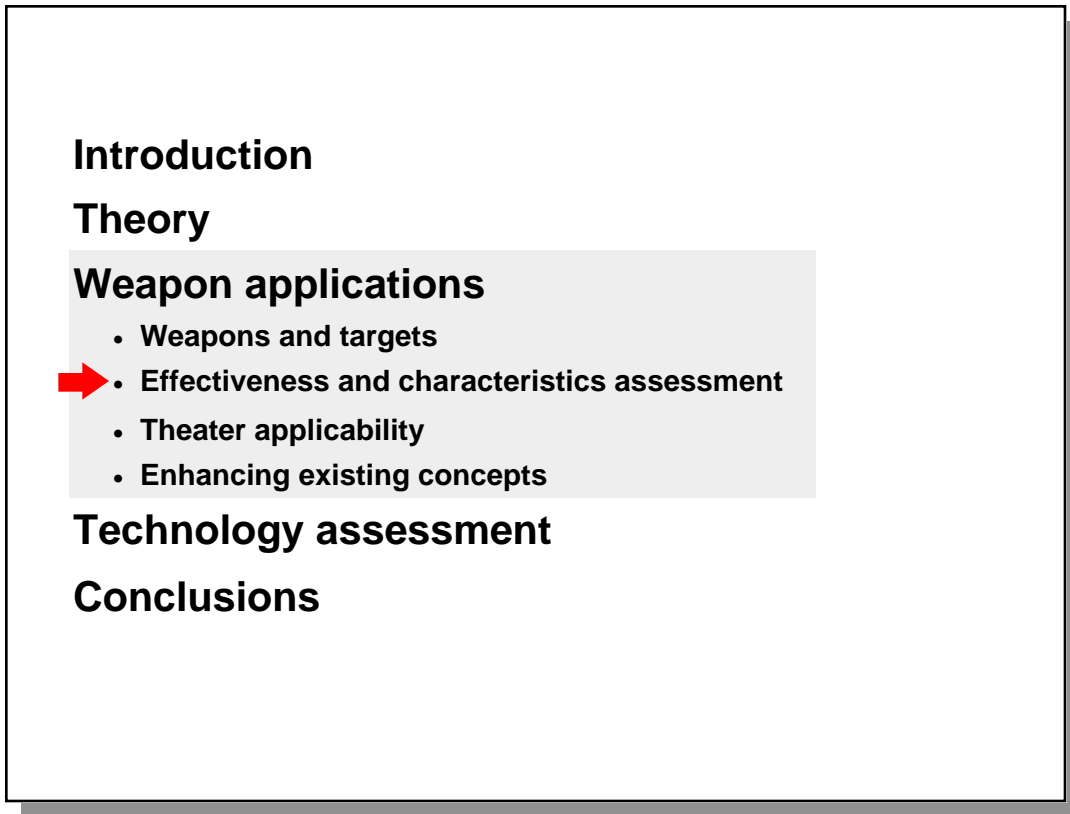
As we shall demonstrate subsequently, the swarming that results from cooperative behavior logic functions effectively against such targets; whereas, without good knowledge of the target layout, it is difficult for systems not having communications to adapt and successfully attack unknown target layouts.



**Figure 3.9—Functional Representation of a Single Mobile Air Defense Target Cluster**

In stylized fashion, the above figure illustrates the composition of one clump of air defense targets. The complex includes radars, missile launchers, and command and control vehicles.

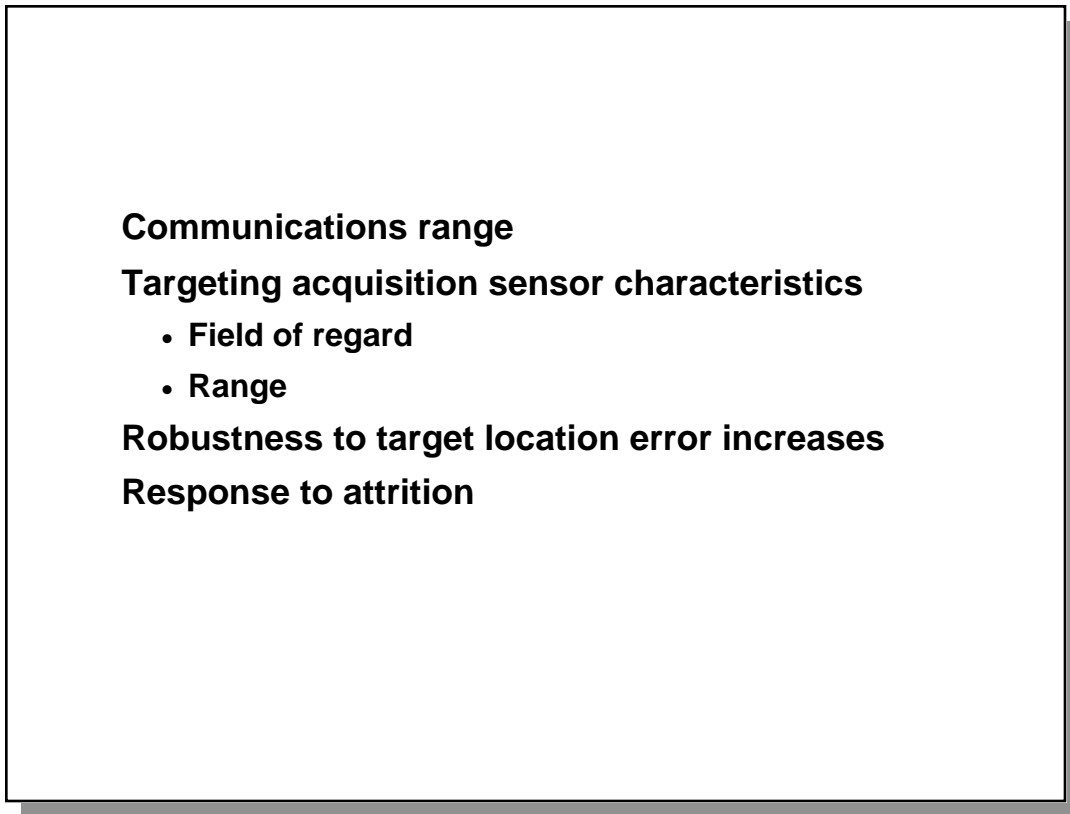
We will compare the effectiveness of weapons that use cooperative behavior logic (through communications across a swarm of weapons) and those that do not against both a single air defense target cluster and a clump of five.



**Figure 3.10—Outline, Effectiveness and Characteristics Assessment**

We will now illustrate the effectiveness of weapons using cooperative behavior and use those results to infer desired characteristics for the weapons.





**Figure 3.11—Critical Issues Examined**

Some of the most critical issues we examined are depicted above. In the case of communications, we were interested in the range needed for the communications system. In the case of the target acquisition sensor, we wanted to examine whether communications and cooperative behavior logic could reduce the sensor field of regard<sup>14</sup> needed and whether the ranges of emerging LADARs for small (100 pound-class) weapons would provide satisfactory performance. We then assessed the potential for satisfying communications needs using RF or IR systems.

To address these issues, we implemented a simulation of autonomous vehicles using an approach that exploited the concept of contention inherent in the subsumption architecture. Rather than focusing on control of vehicle subsystems, we focused on the higher-level interaction of behaviors such as seeking targets, attraction, repulsion,

---

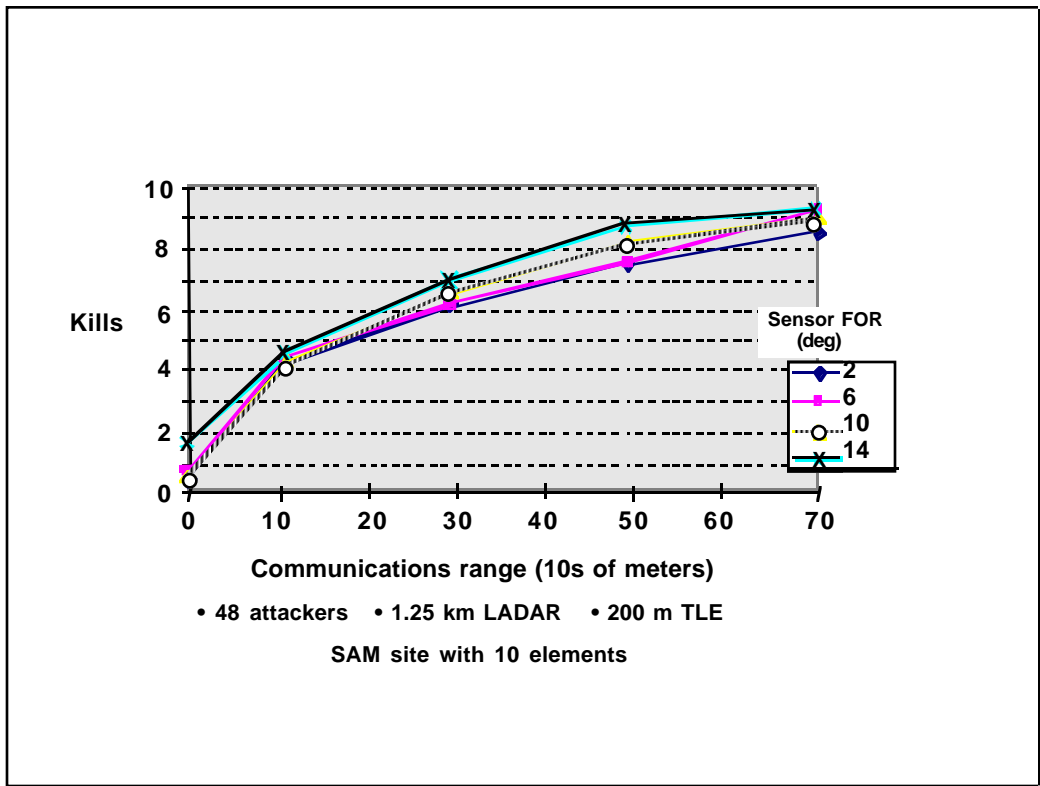
<sup>14</sup>Field of regard is defined as the total angular coverage of the sensor.

and attacking. These behaviors were placed in contention with one another, and we used the simulation to examine the issues of self-organization and system effectiveness as functions of how these relatively simple behaviors interacted with each other, and technical characteristics of the weapons such as seeker range, field of regard, and communications range.

We used the *Swarm* simulation system, developed by the Santa Fe Institute, to construct the simulation of our autonomous weapons.<sup>15</sup> *Swarm* is used in the research community for the creation of large agent-based models without requiring the extensive development of lower-level simulation code. *Swarm* has been used for large-scale simulation of artificial life, computational economics, the study of autonomous vehicles and robotics, and in our case, the assessment of cooperative behavior between simple autonomous weapons equipped with short-range communication systems.

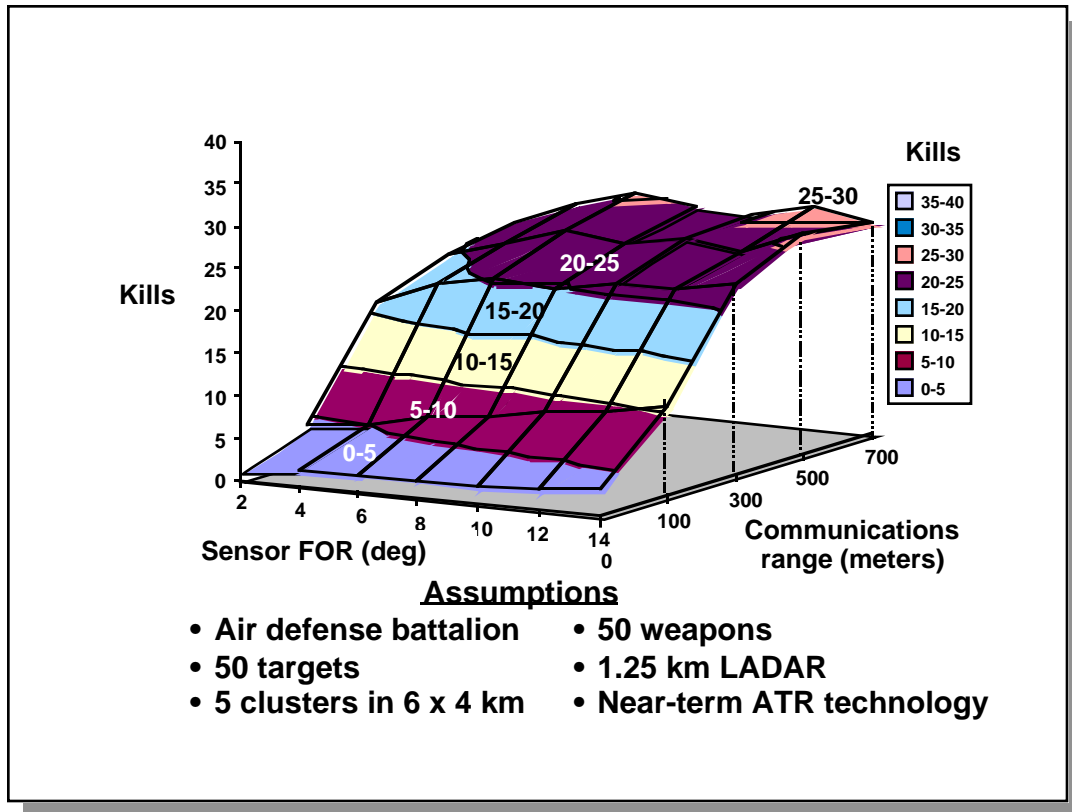
---

<sup>15</sup>The Santa Fe Institute maintains a World Wide Web site that describes the *Swarm* simulation system, including the principles of its operation. The computer code itself is also available at this site. See <http://www.santafe.edu/projects/swarm/>.



**Figure 3.12—Swarming Algorithms May Permit the Use of Lower-Capability Sensors**

Communications used in conjunction with swarming algorithms may compensate for the limited field of regard (FOR) of weapon sensors. As communications capability is added, widely varying sensor fields of regard exhibit broadly comparable effectiveness. As the swarming weapons with narrow field of regard sensors spread out using anti-flocking behavior, collectively they can continue to exhibit effectiveness comparable to that of weapons having wider fields of regard by communicating in a rudimentary manner. This provides a potential opportunity to reduce the complexity and cost of the target acquisition sensor, perhaps at least in part compensating for the additional cost of incorporating the needed communications capability.



**Figure 3.13—Improved Communication Enhances Effectiveness More Than Sensor Field of Regard for Large Targets**

The value of communications was apparent when we explored effectiveness parametrically as a function of the sensor field of regard and weapon communications range for the full 50-element target. Adding communications enhanced weapon effectiveness more than increasing the field of regard of the LADAR sensor did. In this example, 50 weapons attacked the air defense battalion having five clusters of targets (each with ten individual target elements) within a relatively large 6 by 4 km area.<sup>16</sup>

When communications were active, the nominal weapon separation once group equilibrium was established was about 50 meters. In the noncommunications case, the group was released with a uniform

<sup>16</sup>Figures 3.8 and 3.9 illustrate the layout of the battalion and an individual target cluster within the battalion, respectively. The simulation used Monte Carlo draws to stochastically develop locations of the target elements from one case to another.

random distribution in a release box designed to cover the target area. Without communications (the zero communications range case) and the weapons spread over a large area, many of the weapons did not encounter targets, even as sensor field of regard increased. In contrast, as the communications range between the weapons was increased, there was a marked improvement in the number of target elements killed.<sup>17</sup> Those weapons that did encounter target clusters alerted those that did not, so more weapons were drawn to targets. This payoff from communications applies even for quite limited sensor fields of regard.

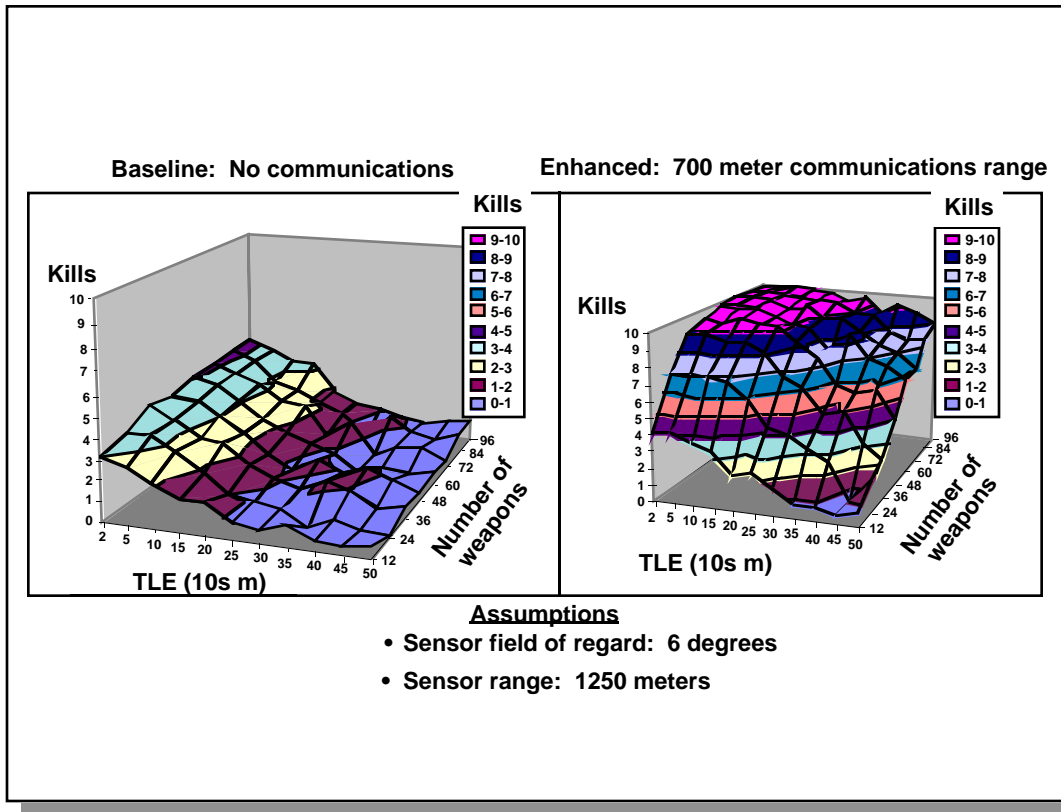
This exploratory investigation relied on a two-dimensional swarm simulation, suggesting that, all other things being equal, weapons using communications may function effectively with smaller fields of regard than those not using communications. However, the two-dimensional swarm model cannot provide definitive answers about how much of the apparent FOR advantage for systems using communications can be realized when other design constraints are applied. Warhead design, guidance concepts, and other factors beyond the scope of the present analysis would shape FOR needs and should be the subject of further research.

There is a cost motivation for reducing sensor field of regard. As FOR is decreased, gimbaled platforms that contribute to increased sensor costs may no longer be required if weapons communicate. Sensors account for a significant fraction of modern weapon costs; hence, this simplification may at least partially compensate for the cost of adding communications while supporting the notion of an affordable proliferated weapon concept.<sup>18</sup>

---

<sup>17</sup>This figure in “line chart” format shows results for the discrete values of communications range explored in the parameter space; hence, the first communications interval shown is 100 meters while the rest are 200 meters.

<sup>18</sup>We will subsequently identify hardware alternatives to gimbaled platforms that may provide scanning performance consistent with the narrower fields of regard characteristic of swarming weapons.



**Figure 3.14—Systems Using Cooperative Behavior Logic Show Greater Robustness to Increases in Target Location Error**

Weapons using cooperative behavior logic exhibit robustness to increases in target location errors (TLEs). The figure above shows performance against a 10-element air defense target cluster for a case without communications shown on the left, and with communications on the right.<sup>19</sup> Without communications, when TLEs are measured in the hundreds of meters, no reasonable amount of additional weapons can compensate for the reduced effectiveness.<sup>20</sup>

A “plateau” of relatively high kill levels characterizes the case when weapons have communications, shown in the figure on the right, even

<sup>19</sup>This figure in “line chart” format shows results for the discrete values of TLE explored in the parameter space; hence, the first TLE interval shown is 30 meters while the rest are 50 meters.

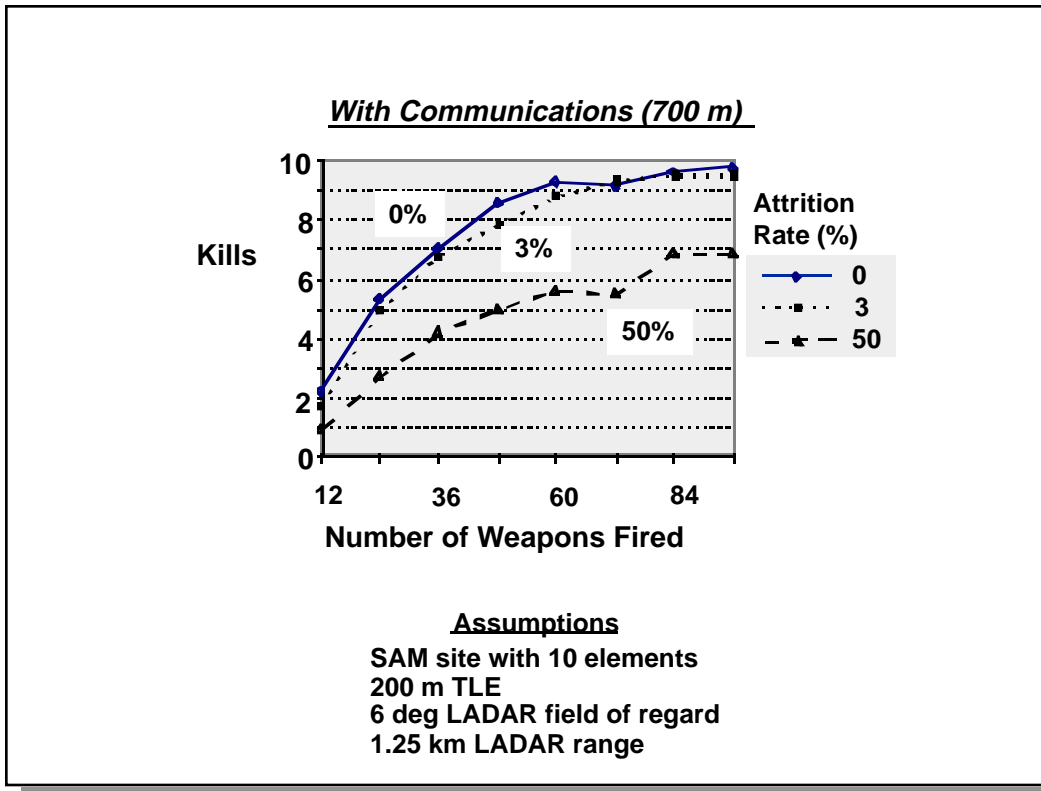
<sup>20</sup>In this no communications case, the weapon release box was set to produce about 50-meter average spacing between weapons.

for quite large TLEs. Conventional weapons currently in the Air Force inventory do not exhibit this kind of robustness to TLE, with the possible exception of homing missiles such as HARM, whose cost is measured in the hundreds of thousands of dollars and whose operation generally requires a radiating target.<sup>21</sup>

As enemy SAMs and other targets have become more mobile, it has become increasingly difficult for intelligence, surveillance, and reconnaissance (ISR) assets and the command, control, and communication (C3) system to localize these targets to high degrees of accuracy. Driving down TLEs so that GPS/INS weapons can be used against these targets can involve large investments, or alternatively, require use of costly anti-radiation weapons. Systems using cooperative behavior logic may provide an alternative approach for dealing with large TLEs at lower cost than some of the competing alternatives.

---

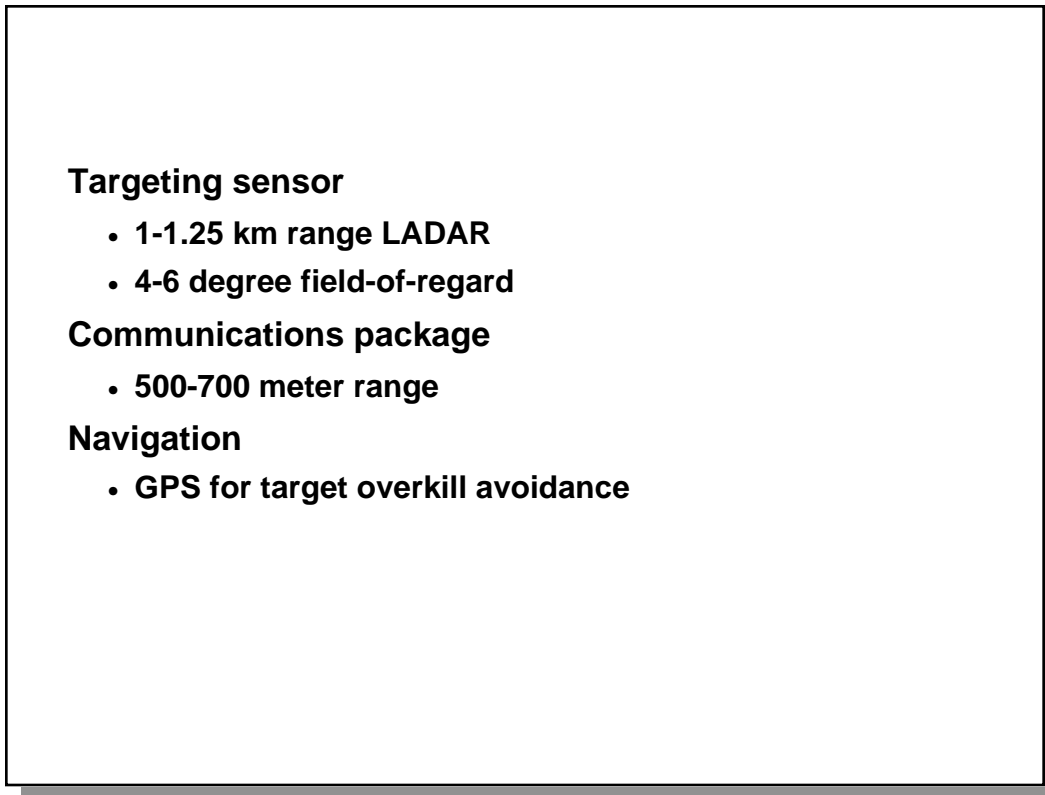
<sup>21</sup>It is too early to make definitive estimates of cooperative system costs, but we expect unit costs in the several tens of thousands of dollars, broadly comparable to perhaps a powered LOCAAS.



**Figure 3.15—Systems Using Communications and Cooperative Behavior Logic Can Exhibit Swarming Even at High Levels of Attrition**

Communications and cooperative behavior logic allow weapons to continue to exhibit the desirable attributes of swarming even at very high levels of attrition. If weapon costs can be kept relatively low, this opens up the possibility of using attrition-tolerant warfare concepts.





**Figure 3.16—Sensor and Communications Systems Characteristics  
Derived from Effectiveness Assessment**

We exercised the *Swarm* simulation to obtain insights about desirable characteristics for the swarming weapons. Simulation results suggest sensor, communication, and navigation characteristics falling in the general range shown above could yield satisfactory effectiveness. Ten characteristics of the LADAR and communications package were derived through an assessment of how different combinations of sensors (defined by a detection range and field of regard) and communications packages performed against a variety of target arrays. The LADAR's characteristics (1-1.25 km range/4-6 degree field of regard) and the communications package nominal range were established based on a large-scale search of the trade space. The final set of characteristics seem to be on a performance plateau that allows for effective utilization of the swarming algorithm developed during the study, while avoiding the problems induced by excessive correlation between different portions of the swarm of weapons that


might occur with longer communications ranges.<sup>22</sup> Other algorithms might require different sensor characteristics; however, our research established, for a simple and relatively robust set of algorithms, an achievable level of hardware characteristics to support those algorithms.

The inclusion of GPS using standard military P-code provided accurate timing and navigational information for the swarm of weapons, provided a collective gridlock after release, and assisted in identifying the location of targets being attacked. Simple on board IMUs probably would be sufficient, but GPS reception facilitated a number of other technical approaches and was very attractive.

A technology assessment, the results of which will be presented in Section 4, suggests that weapons having these characteristics can be designed using current or near-term technologies.

---

<sup>22</sup> The LADAR's range is consistent with state-of-the art LADARS, and therefore would not represent a major development risk. A field of regard in the 4-6 degree range allows for the possible use of non-gimbaled sensor arrays such as we discuss later. Similarly, the communications package nominal range allows for the possible use of a number of commercially derived technologies to facilitate the communications.

<b>Introduction</b>
<b>Theory</b>
<b>Weapon applications</b>
• Weapons and targets
• Effectiveness and characteristics assessment
 • Theater applicability
• Enhancing existing concepts
<b>Technology assessment</b>
<b>Conclusions</b>

**Figure 3.17—Outline, Theater Applicability**

By comparing weapon characteristics with the type and number of targets in typical MTW scenarios, we assessed the potential applicability of weapons using communications and cooperative behavior logic in a theater context.

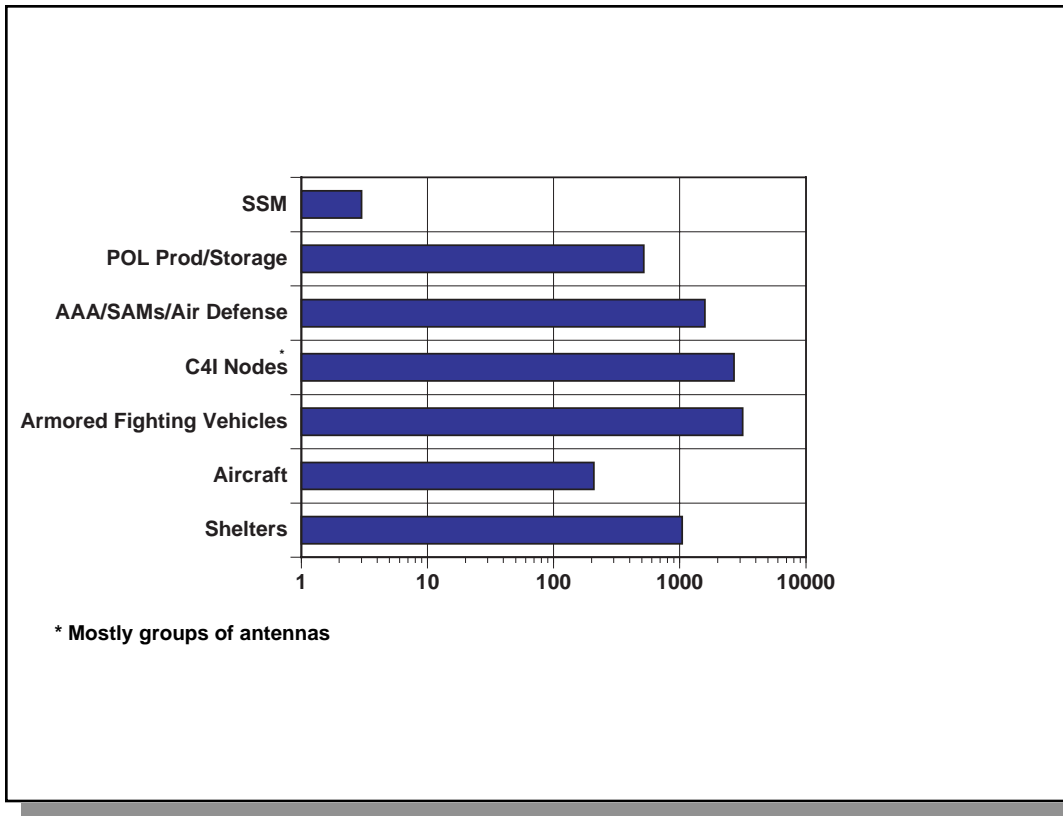
**Poorly localized, non-uniformly distributed**  
**Many individual vulnerable points**  
**Specific aimpoint selection not important**  
**Mission planning might be costly relative to the benefits**

- **Numerous moderate-value targets (e.g., weapon storage bunkers)**

**Defended targets where adaptivity to attrition is desired**

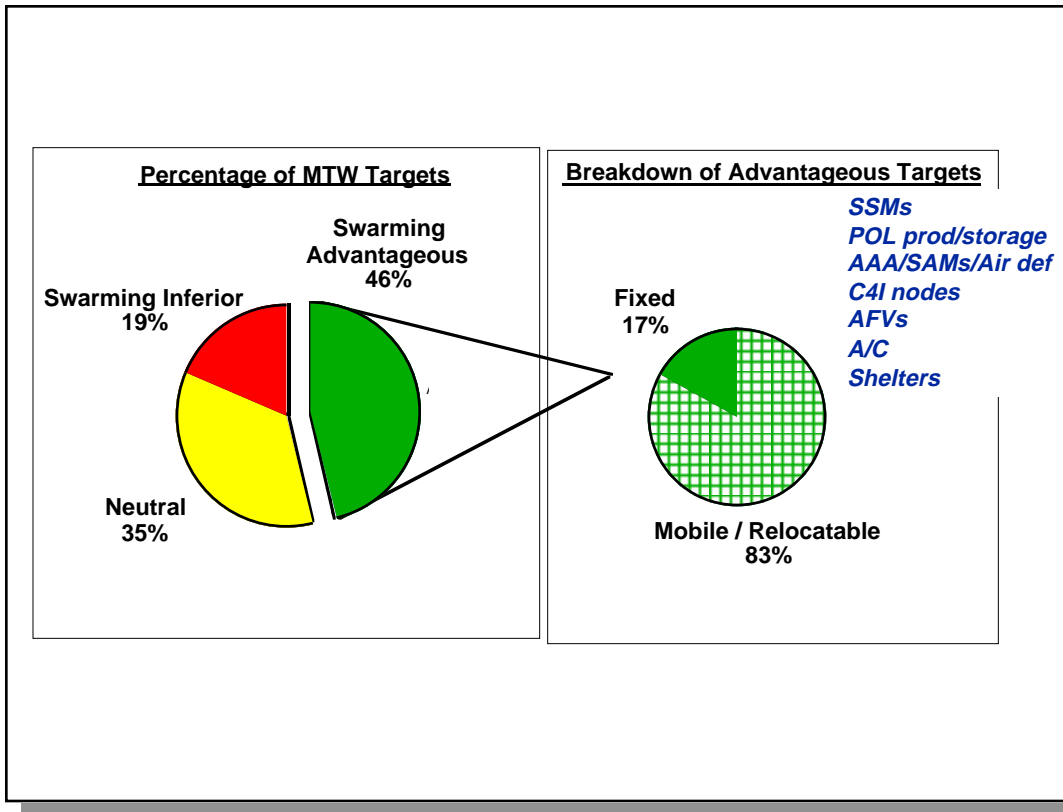
**Figure 3.18—Attributes of Targets Most Suitable for Attack by Weapons Exhibiting Swarming Behavior**

Listed above are the attributes of targets that seem most suitable for attack by systems that exhibit swarming behavior. In general, these targets have locations that are not well defined, tend to not be uniformly distributed, and have many individual vulnerable points. Targets requiring fine-grained targeting are not particularly suitable for such weapons (e.g., a specific air shaft of a C3 bunker). The “virtual mission planning” that emerges from the behavior of such weapons could, however, make them particularly useful against certain moderate-value targets that today impose a large burden on the mission planning process. Because swarming weapon behavior is reasonably robust to attrition, such weapons could find an important role in attacking targets where attrition is expected.



**Figure 3.19—Number of Targets for Which Swarming Behavior Offers Advantages**

In principle, thousands of targets are amenable to attack by swarming weapons in an MTW. The figure above shows the quantitative distribution of targets for which swarming weapons seem most suitable. By comparing these results with the counts of other targets in an MTW that are less suitable for attack by swarming weapons, we can assess the fraction of the overall MTW target set that swarming weapons might address.



**Figure 3.20—Swarming Weapons Are Potentially Advantageous for a Significant Portion of an MTW Target Set**

We applied the following criteria to categorize the fraction of the MTW target set amenable to attack by weapons using swarming behavior as compared with more conventional approaches.

Swarming weapons regarded as advantageous

- Large TLEs
- Significant decrease in target material preparation
- Collateral damage not a significant issue

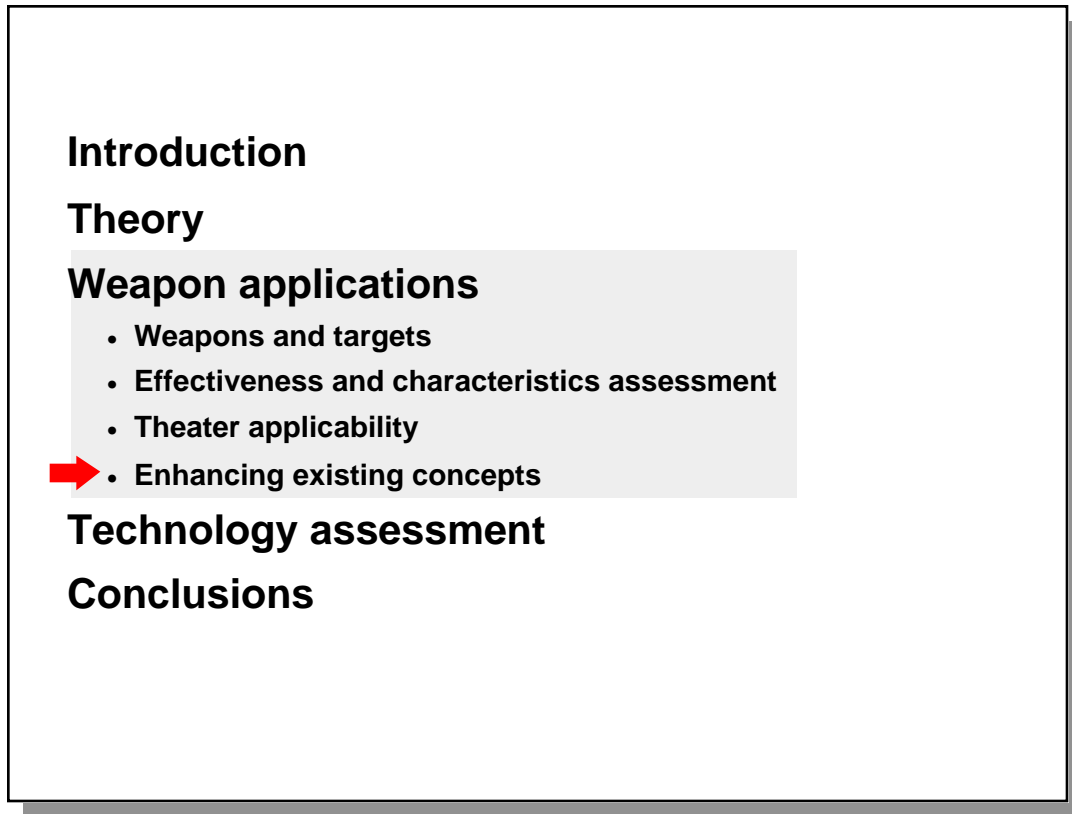
Neutral

- Small TLE
- Many equal-value target elements
- Autonomy does not help much, or hurts with regard to mission planning problem

### Swarming weapons regarded as inferior

- Very small vulnerable area
- Small number of critical elements
- Autonomy complicates mission planning problem

Applying these criteria, weapons that use swarming behavior appear to offer an advantage over more conventional approaches for slightly less than half of an MTW target set. About 83 percent of these targets fall in the mobile/relocatable category, with the remainder in the fixed target category. Multiple versions of the swarming weapons tailored to particular classes of targets would undoubtedly be required to service this broad spectrum of targets.



**Figure 3.21—Outline, Enhancing Existing Concepts**

Emerging developmental weapons could provide an opportunity for demonstrating key aspects of the technologies needed for weapon concepts that rely on cooperative behavior, thus helping to reduce the risks of undertaking a new cooperative weapon system concept. We have explored how the addition of communications could enhance the performance of the Damocles concept, a weapon whose initial development has been sponsored by DARPA.

Damocles is a multipurpose autonomous intelligent submunition concept developed by Textron Defense Systems that is designed to find, discriminate, attack, and kill high-value targets, including command posts, tactical surface-to-surface missile systems and their support vehicles, mobile air defense units and arrays, and other light armored vehicles.<sup>23</sup>

<sup>23</sup>Gary Grant, Dean Risseuw, Dick McConville, *Damocles, Smart Munitions Study Data Sheets*, Textron Defense Systems, 24 February 1995.



### **Damocles example**

- **Baseline: Smart submunition with simple logic**
- **Improved: Counting logic**
- **Augmented: Communications**

### **Target array**

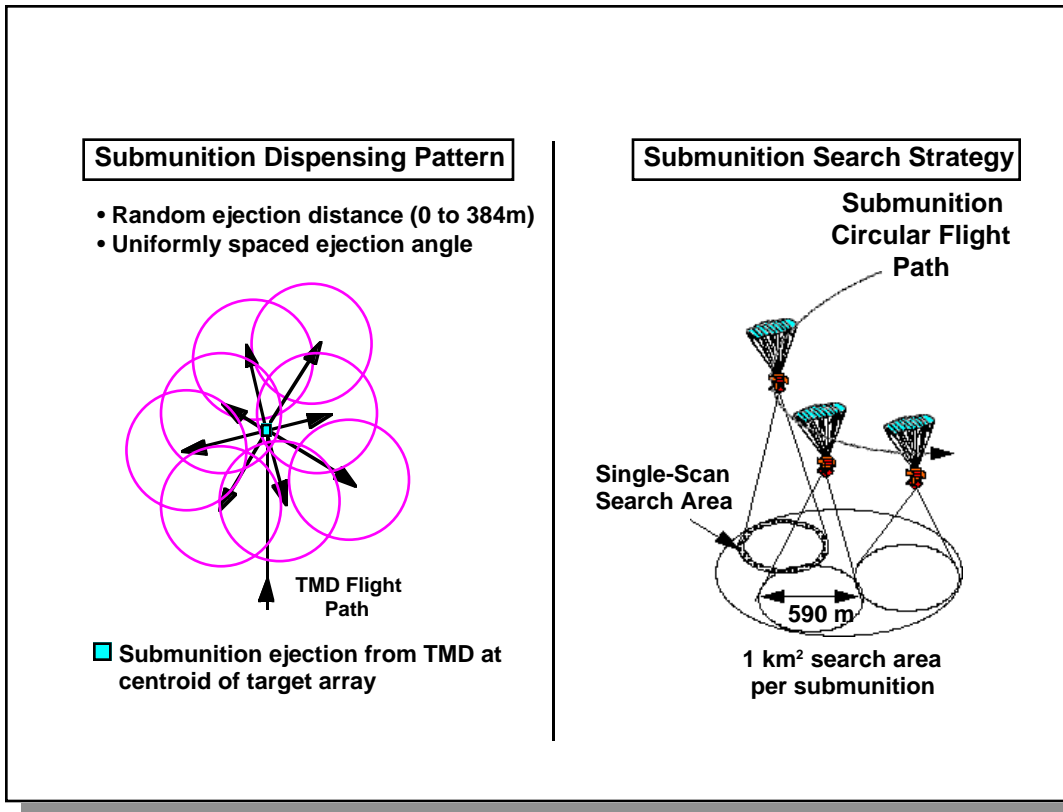
- **Air defense fire unit (10 elements)**
- **Multi-site air defense unit (50 elements)**

**Figure 3.22—Simple Communications Can Also Be Added to Existing Weapons to Boost Performance**

We investigated two different approaches for enhancing Damocles effectiveness. First, we added a counting algorithm that is internal to each submunition to lessen the incidence of excessive submunitions being committed to the same target in an array. Alternatively, we added communications so submunitions were aware of the commitment of submunitions to individual target elements and could act to avoid over-commitments to individual targets.<sup>24</sup> This provided a means to compare communications with a simpler implementation intended to achieve a similar effect. This comparison reflects what might be done within the framework of an existing weapon concept; hence, it does not include a full implementation of the swarming algorithms.

---

<sup>24</sup>Submunitions would use a combination of their onboard sensors and GPS/INS to characterize the location of individual targets.



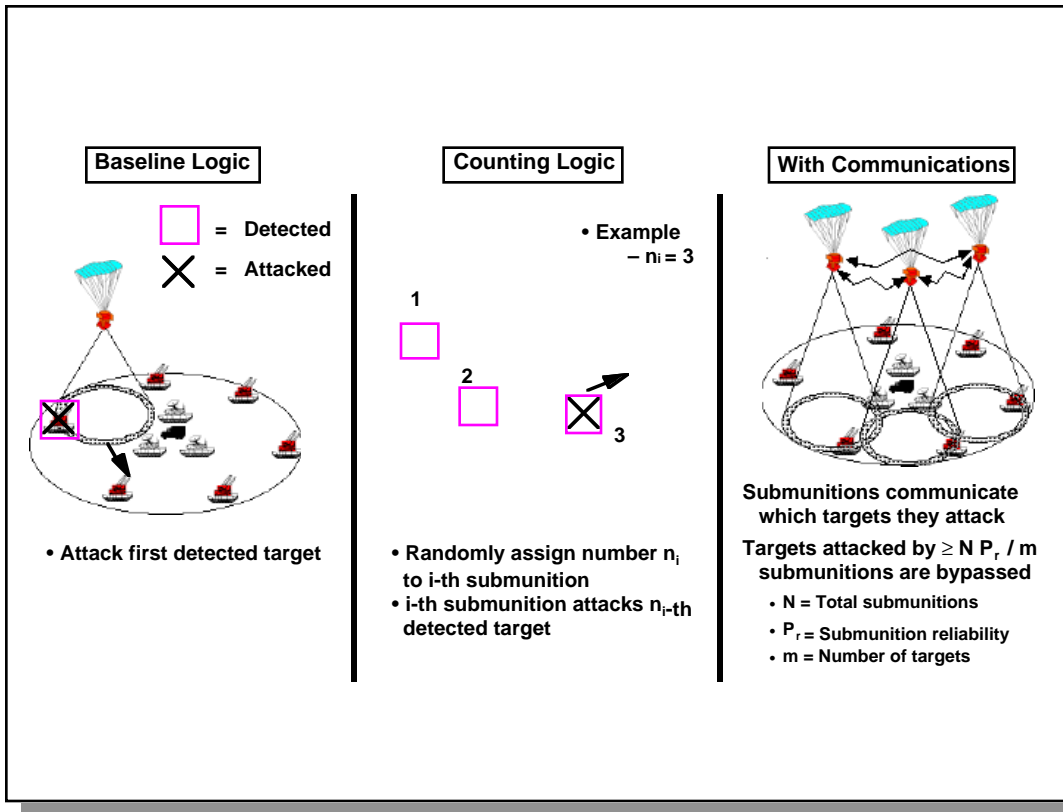
**Figure 3.23—Damocles Operational Concept**

The figure above illustrates operation of the Damocles. Typically, the submunitions are ejected along various azimuths over the target array centroid by standard dispensers such as the Multiple Launch Rocket System (MLRS) or Tactical Munitions Dispenser (TMD). Each submunition deploys a steerable glide chute to search for stationary or maneuverable targets as the weapon descends along a 4:1 glide slope. An onboard IR sensor is rotated conically at 3 Hz by spin vanes to scan an annular ring, which results in a tight helical search pattern on the ground as the chute advances. The sensor's nadir angle is adjusted during the descent to keep the radius of the helix constant. If a circular glide path is selected, as indicated in the figure, each submunition is capable of searching a 1-km<sup>2</sup> circle. When a target is detected, it is classified by automatic target recognition (ATR), and tracked. While maintaining track, the submunition effects a controlled, rapid descent.

It then maneuvers to within lethal range, and the sensor-fuzed warhead is fired at the target.<sup>25</sup>

---

<sup>25</sup>*Damocles—Autonomous Intelligent Submunition*, briefing presented to Col William Ervin, by Textron Defense Systems, Wilmington, Mass., 5 November 1993.



**Figure 3.24—Target Designation Logic**

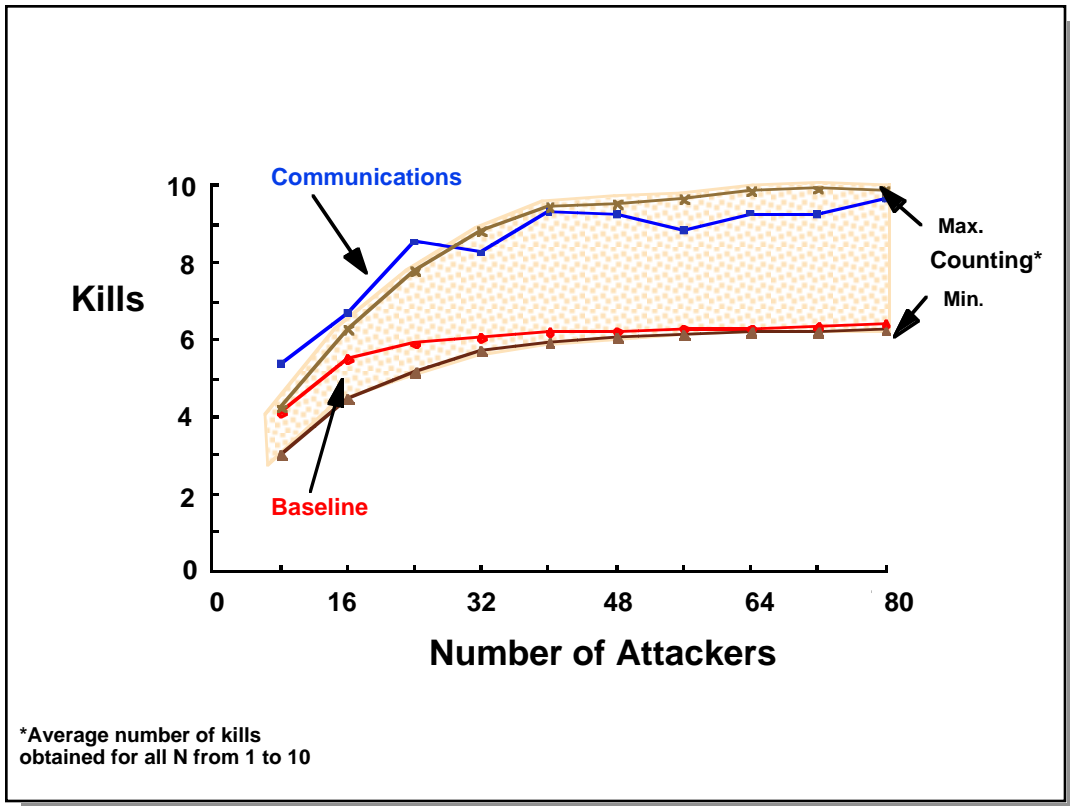
In the baseline Damocles logic, submunitions attacked the first detected target. For the target array we were evaluating, this tended to result in heavy commitments of submunitions to target elements on the perimeter of the array, while many target elements in the interior of the array were left untouched.

The counting approach illustrated in the center panel of the figure randomly assigns a number to each submunition that reflects the number of target detections the submunition will accumulate before commencing an attack. This helps to reduce excessive commitments to individual target elements.

The third approach illustrated in the rightmost panel assumes communication among submunitions coupled with a limit on the number of weapons committed to an individual target. The limit is based on an intelligence estimate of the number of targets in the area, which is loaded prior to launching the weapon dispenser. For example, in a SEAD mission one might have knowledge from ELINT of

the number of mobile SA-10 batteries in an area, although their locations may be uncertain. In order to communicate which targets are under attack, the aimpoints are specified by their location (derived from the onboard GPS/INS system), and the identification provided by the ATR.

We implemented these three approaches in RAND's MADAM munitions evaluation program against the same 10-element air defense array described earlier and observed the comparative effectiveness of the approaches.



**Figure 3.25—Communications Provide Greatly Enhanced Effectiveness**

This figure shows results for average number of kills derived from Monte Carlo runs of RAND’s MADAM code. In general, the baseline concept, with no counting or communication, tends to yield lower effectiveness. The approach using communication tends to yield higher effectiveness, with fairly consistent outcomes. Outcomes using the counting approach vary over a wide range, depending on whether the counting rule can be optimized for the specific target array. Since it is unlikely that one could always anticipate the layout of target arrays and conveniently set counting algorithms to maximize effectiveness, we concluded that the communications approach holds an effectiveness advantage.<sup>26</sup>

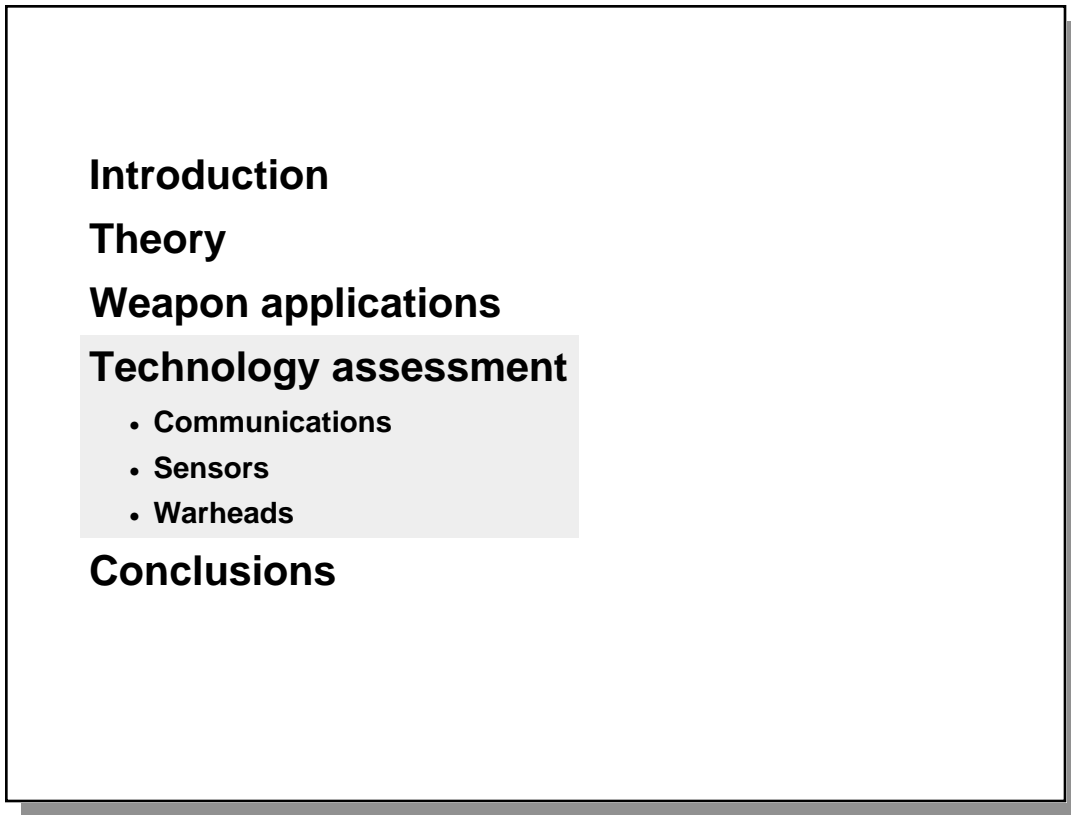
<sup>26</sup>A more comprehensive analysis would be needed to conclude whether one approach holds a *cost-effectiveness advantage* over the other.

In the baseline case, each submunition attacks the first target it encounters in its helical search pattern. In a large cluster of targets, this will usually result in attacking and reattacking targets positioned on the periphery of the cluster. These peripheral targets will chalk up large numbers of hits, but unless the kills modify the target signatures to a degree that renders them unrecognizable, they will in effect act as decoys for the targets in the cluster's interior. We assumed in this analysis that the signatures of killed targets were not discriminable, which is consistent with the current state of the art of weapon ATR.

In the counting approach, the weapon counts some random number of detected targets before attacking one. The random number is chosen between zero and  $N$ . The question is, what is  $N$ ? If the target array configuration is known, one can choose  $N$  so that the submunitions will reach, detect, and kill the innermost targets. If  $N$  is too small, some targets will not be attacked, and others will be subjected to overkill. If  $N$  is too large, some weapons will be wasted. The band between the minimum and maximum number of kills using the counting rules corresponds to  $N$  taking all integer values between 1 and 10.

Communications offers the best performance overall because it provides more information to optimize the attack. Specifically, it puts a cap on the number of weapons that can be assigned to each target, and informs each submunition how many weapons are drawn to each target. It does not degrade as a result of ignorance about the target array configuration, but does require a reasonably good estimate of the total number of targets. If the estimate is seriously in error, the allocation of weapons to targets will be uneven, with the targets on the periphery of clusters receiving more than their share. Our analysis did not assume that the estimate of target count could be revised based on detection and location information collected by the submunitions, or that further attacks on a target could be curtailed by an ATR that discriminates live from killed targets. These features are possible, but more advanced than we desired to treat at this stage.

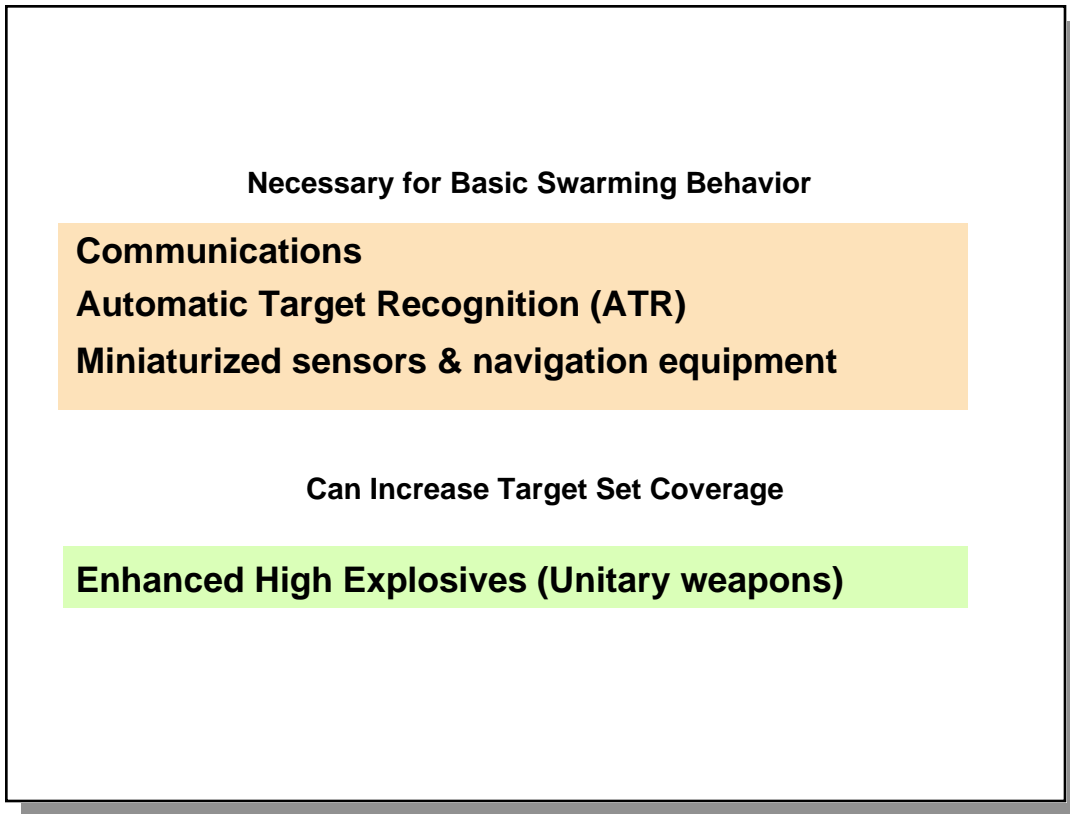
## 4. TECHNOLOGY ASSESSMENT



**Figure 4.1—Outline, Technology Assessment**

Our applications assessment suggested in broad terms the kinds of weapon characteristics needed to yield satisfactory performance. We then assessed technical approaches for achieving those weapon characteristics.

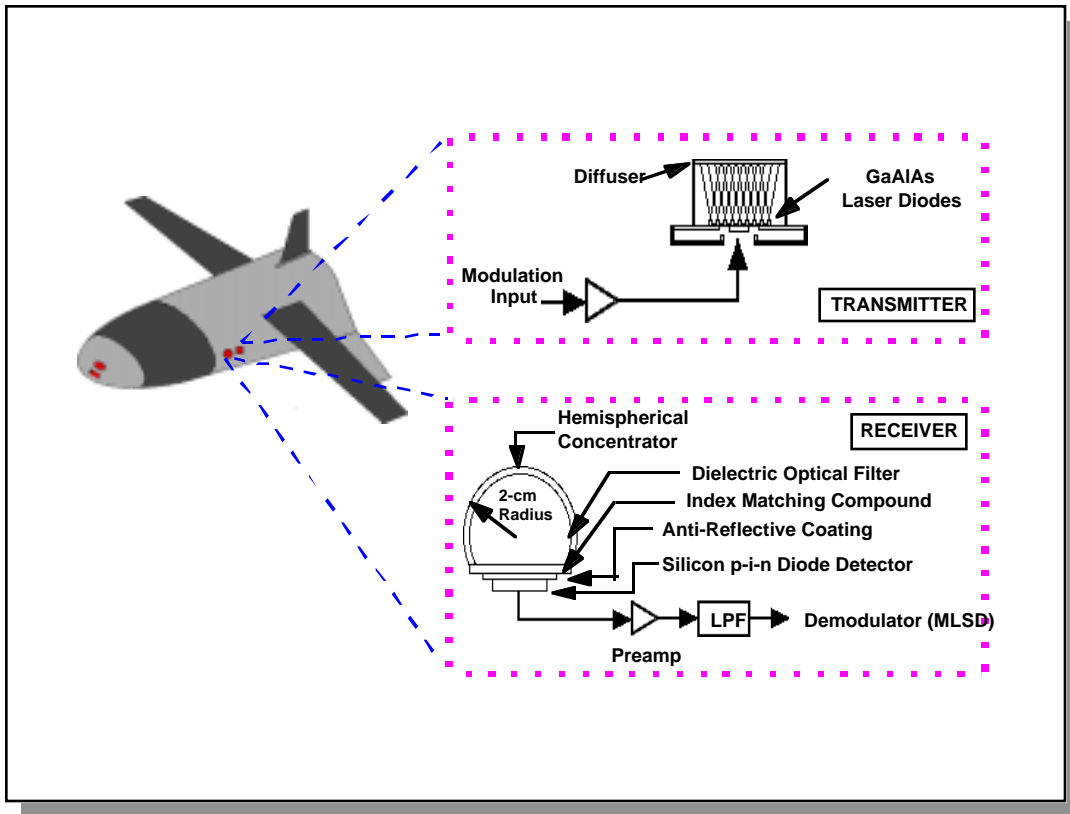




**Figure 4.2—Critical Supporting Technologies for Proliferated Systems**

Three of the four technologies noted above are needed to make a swarming weapon concept viable. The fourth, enhanced explosives, could help to broaden the set of targets attackable by swarming weapons. This latter technology encompasses energetic materials and better warhead case design.

We focused our analysis efforts on the first three technologies necessary for realization of the swarming weapon concept.



**Figure 4.3—IR Communications System Block Diagram**

Our development of the behavior logic used in the *Swarm* simulation roughly established the size of the messages that would have to be passed from one weapon to another. The requirement to pass a weapon ID code, current weapon location (within a finite grid), target location, etc., suggests a need for a message size of approximately 60 bits. The effectiveness analysis established communications ranges, and the end-to-end communications delay (or update interval) that could be tolerated. We explored the ability of both IR and RF communications systems to satisfy communications needs. We will briefly summarize what we learned about each communications approach.

A block diagram of a notional IR system is shown above. It follows closely the design of some existing IR wireless local area network (WLAN) transceivers that employ intensity modulation, line-of-sight propagation, and direct detection. Apertures would be spaced around the weapon, and their fields of view sized to ensure that they could communicate with adjacent weapons omnidirectionally and in the full

altitude band over which they are spread. Transmissions would be accomplished by multihop dissemination across weapon formations.

The transmitter consists of a modulator, which converts the digital input stream to RF waveforms, and a GaAlAs laser diode array (typically an LED or single laser diode in conventional WLANs) that is modulated by the RF signal intensity. The illumination of the arrayed semiconductor lasers is formed noncoherently into a single beam by a diffuser.

The receiver consists of a hemispherical concentrator, which refracts the light in the field of view onto the detector plane; a dielectric optical filter on the concentrator's inner surface, which reduces out-of-band noise; a silicon p-i-n diode detector, which converts the modulated light to an electrical signal; and circuitry to amplify, filter, and demodulate the signal to recover the digital datastream.

Multipath interference is commonly a limiting factor in the performance of IR WLANs, resulting from either bounced signals when the environment is indoors, or from multiple-delay transmissions when, as is the case here, the signal is disseminated through multiple hops. The effect of multipath is mitigated by channel equalization techniques or the method selected here, the maximum likelihood sequence detector (MLSD).

The communications protocol we assumed is a form of synchronous, time-slotted simulcast. Each weapon is assigned a slot during which it broadcasts its status, and information pertaining to that same weapon is repeated on subsequent cycles by any weapons receiving the message. Network timing for synchronization is provided by GPS. During successive rebroadcasts, each weapon's information flows outward, reaching the extremities of the swarm of weapons in a number of hops that depends on the size of the swarm of weapons and the single-hop range.

Commonly used modulation schemes for IR WLANs include on-off keying (OOK) and M-ary pulse position modulation (PPM). A key design trade-off in our assessment was to select the modulation that best minimized the transmitter power as a function of the size of the swarm of weapons. With a larger weapon swarm, the larger number of rebroadcasts forces the bit rate up, in order to meet a fixed refresh rate requirement. This results in higher intersymbol interference losses, particularly for PPM. For a weapon swarm larger than 600m across, OOK is the modulation of choice.

### **Infrared links connecting swarm weapons having a total separation of 500-700m are feasible**

- **Most of the required components are COTS available**
  - Indoor WLAN for computers, etc.
  - Infrared Data Association (IrDA) standard links and protocols (up to 4 Mb/s)
  - Phillips Lab secure portable laser comm (1 km range)
- **Ruggedized packaging suitable for military applications must be provided**
- **Existing commercial protocols may not support intra-swarm communications, but with applications mushrooming, this could change in the near term**

### **IR communications are widely regarded as LPI**

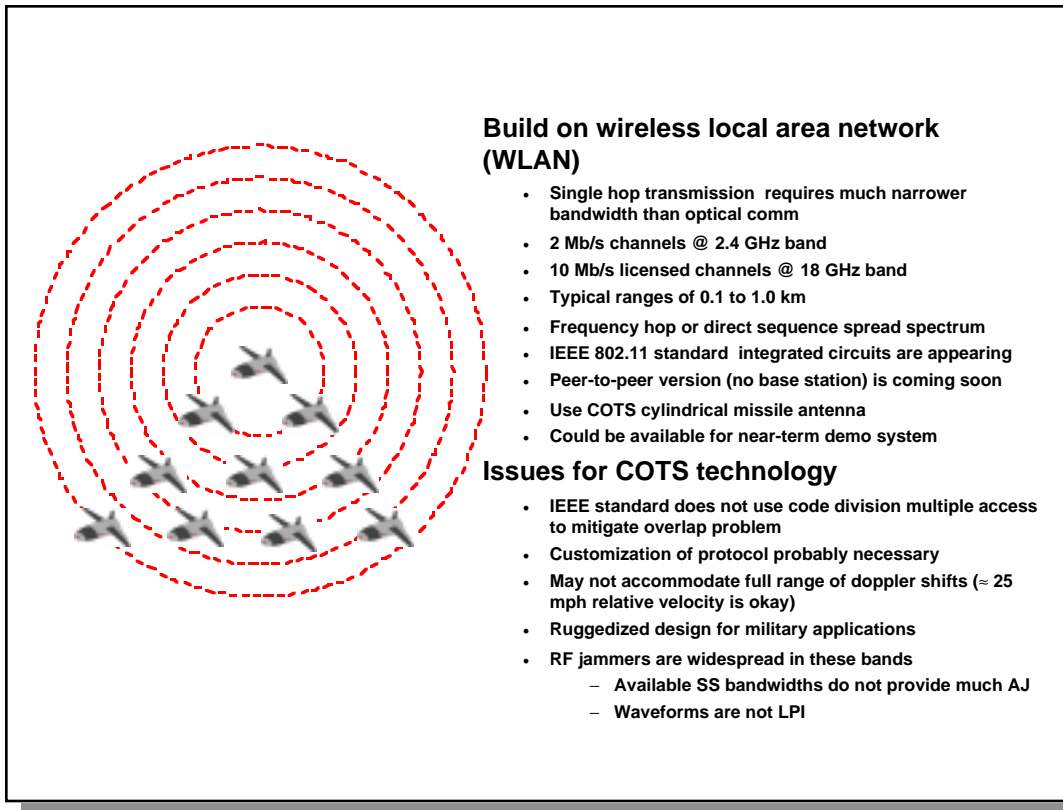
- **Intercept receivers and jammers are not currently deployed**
- **Planning for threats should include development of higher power, spread spectrum systems (adequate bandwidth available)**

**Figure 4.4—Observations About IR Communications Option**

Our assessment indicates the feasibility of infrared links for swarm communications at the 500 to 700 meter ranges needed for the concept. Most of the components would be available commercially off the shelf (COTS), although some ruggedized packaging would probably be needed for a weapon application. The LED or laser diode commonly found in commercial equipment would have to be upgraded to a 3–6 watt laser diode array. (Much higher power laser diode arrays are available commercially.) Additionally, it is not clear whether existing commercial protocols will support swarm communications, and hence this could be a system area requiring development attention.

A big advantage of IR communications is that they are currently difficult to intercept or jam. We have not been able to identify any equipment in the inventory of the United States or other countries that is specifically designed to intercept or jam IR LANs. Should threats develop, there is adequate bandwidth to accommodate spread spectrum (SS) approaches and higher power transmitters to improve performance in a jamming environment.

Of course, atmospheric attenuation resulting from clouds and fog is a potential problem for all optically based sensors. This applies to the laser radar terminal sensor as much as to the IR communications. In a sense, the overall weapon design is balanced with respect to sensing and communicating, and there is no pretense of achieving all-weather capability.



**Figure 4.5—Radio Frequency Communications Option**

The RF communications option builds on wireless local area network technology. In contrast to the IR communications approach, single-hop transmissions would be possible with RF across the weapon formation. Commercially available antennas appear viable for this application, and indeed most critical elements of an RF communications system could be available in the near term for a concept demonstration.

The RF option shares with the IR option the possible need for ruggedization and the possible need for the development of custom protocols. In contrast to an IR system, an RF system could be susceptible to jamming in its bands of operation. This area would require attention if an RF communications system were to be incorporated in an operational system.

- **Current algorithms in small weapon applications use range data, focus on size templates**
- **Ongoing research examining feature extraction and 3-D model template matching**
- **DSP technology advance will support greater levels of performance**
- **Near-term ATR performance will be adequate for ELINT-cued attack in areas where false target hits are acceptable**

**Figure 4.6—LADAR Automatic Target Recognition**

The LADAR-equipped LOCAAS weapon relies on an ATR algorithm to identify targets. Our effectiveness analysis suggests that the performance of such a system would be adequate for ELINT-cued attacks by swarming weapons assuming some false target hits were acceptable. A swarming weapon concept could, of course, benefit from better ATR algorithms, and hardware and software developments are under way that would support better performance.

### **Gimbal**

- **Currently required to scan large LOCAAS FOR**
- **Contributes substantially to weight and cost**

### **Alternative scanning methods**

- **Scan laser with mirror, receive with staring FPA**
- **Optical space-fed phased array (liquid crystal)**
- **Frequency steering (frequency agile laser + grating)**
- **Micromirror array (currently adaptive optics only)**
- **Binary optics (diffractively produced beams  $\leq 2$  deg)**

**Figure 4.7—Laser Radar Scanning Technology**

The effectiveness analysis of swarming weapons indicated good performance for 4–6 degree fields of regard because of the compensating effect of communications among weapons. This comparatively modest field of regard requirement may permit the use of less complicated scanning mechanisms for laser radar sensors. We identified several potential alternatives to the more traditional gimballed scanning approach. Each has advantages and risks, but deserve consideration as possible approaches for achieving lower weight and cost.



**More energetic explosives and better case designs can increase effectiveness per unit weight and volume**

- potential for factors of 1.3 (year 2000) to 4 (2020) improvement in energy enhancement over conventional high explosives
- new case design initiatives demonstrate potential for greater penetration in smaller packages
- JAST-1000 effort explored potential for designing 1000-lb weapon with effectiveness of 2000-lb Mk-84

**Multimode warheads enhance lethality across range of targets**

- capable of producing target-specific penetrators: aerostable slug, long stretching rod, diverging fragments
- ATR algorithms select most lethal mode for target type in LOCAAS concept

**Improvements in case design and energetic explosives could broaden the set of targets addressable by swarming weapons**

**Figure 4.8—Improved Explosives, Case Designs, and Multimode Warheads**

Technology developments in several areas could enhance both the blast and penetration effectiveness of swarming weapons, including (1) energetic explosives, (2) better case designs, and (3) multimode warheads. Energetic explosives plus better design of warhead casings are being used by the Air Force's Armament Laboratory to increase warhead effectiveness per unit of weight and volume.<sup>27</sup> Gains are expected in explosive energy and penetration effectiveness. Over the long term, four-fold increases in energy release over today's explosives may be possible.

---

<sup>27</sup>*Hard Target Penetrators*, briefing to Air Force Scientific Advisory Board by Al Welle of Wright Laboratories, Armament Directorate, 8 February 1996; *Energetic Materials Research at WL/MN, Enhancing Lethality of Next Generation Ordnance Packages*, briefing by John Corley of WL/MN to Air Force Scientific Advisory Board, 8 February 1996.

The small smart bomb program has demonstrated that a 250-lb-class weapon can penetrate 6 feet of concrete, though such tests were conducted at far higher impact velocities than envisioned in our approach.<sup>28</sup> New designs for 2000-lb weapons are expected to exhibit substantially better penetration than current weapons of similar size. Innovative case designs and energetic explosives may ultimately permit a 1000-lb-class weapon to approach the effectiveness of a weapon twice that weight.

The Air Force's Anti-Materiel Submunition Warhead Technology program with Alliant Techsystems has developed a lightweight multimode warhead that can generate three distinct penetrators. In the LOCAAS concept for using this warhead, onboard ATR algorithms select the most lethal warhead mode for the particular target type being attacked.<sup>29</sup>

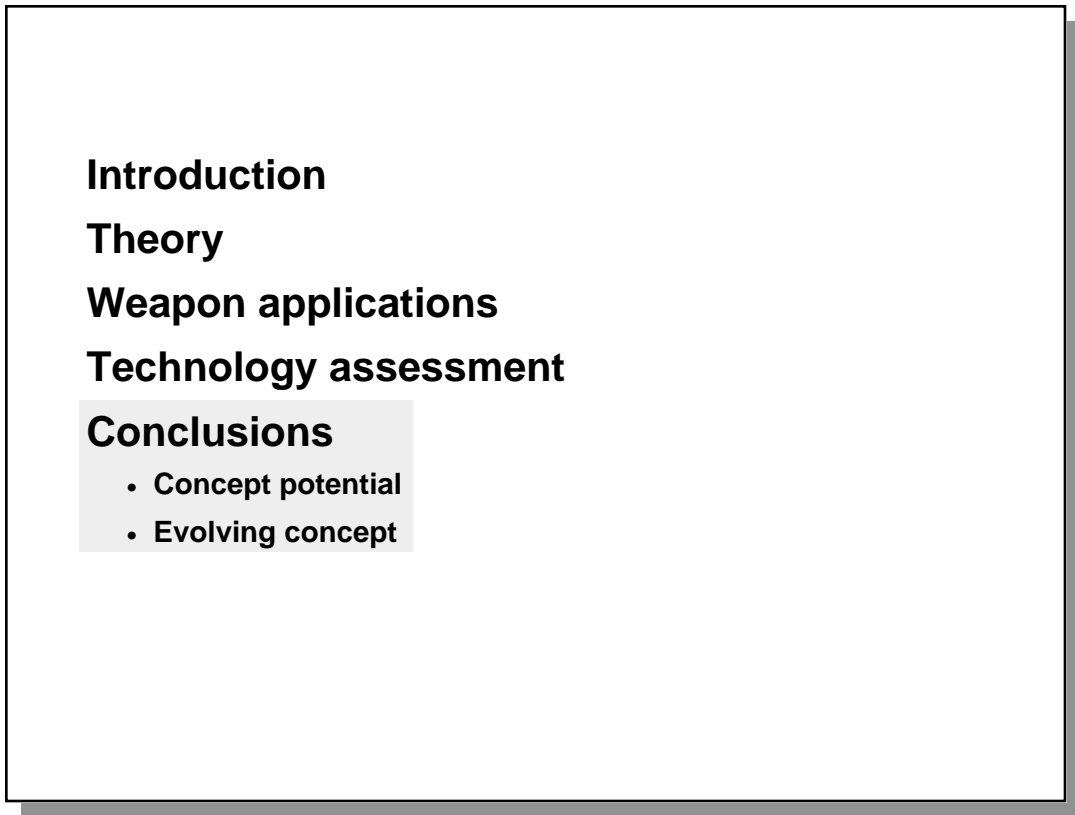
The viability of the swarming weapon concept is not uniquely tied to the success of energetic explosives programs or better case designs, but these R&D programs could allow swarming weapons to address a broader cross-section of targets, permitting them to retain a size small enough to keep the numbers of weapons up while still threatening a significant fraction of the target set. In particular, the improved high explosives would open up an array of blast-sensitive targets that otherwise would not be easily attacked by very small swarming weapons.

---

<sup>28</sup>*Miniaturized Munition Technology Demonstration (Small Smart Bomb Integration Concept)*, briefing to Air Force Scientific Advisory Board by Lt Col Ted Mundelein, Jr., of WL/MNAX, 8 February 1996.

<sup>29</sup>Michael Tower, *Powered Low Cost Autonomous Attack System (LOCAAS)*, Lockheed Martin Vought Systems, August 1996; Major Dave Jacques, *Low Cost Autonomous Attack System, LOCAAS*, Wright Laboratory, Armament Directorate, 1997.

## 5. CONCLUSIONS



**Figure 5.1—Outline, Conclusions**

We now summarize the potential benefits of weapons using cooperative behavior and suggest a possible approach for maturing the weapon concept.

**Potential for significant benefits from integration of group behavior logic and communications**

- May reduce sensor performance requirements
- Greater robustness to increases in TLE
- Adaptivity (to attrition, poorly characterized targets)
- Weapons hit more targets
- Addresses relevant targets not always serviced well today

**Builds on emerging technologies, some commercial**

**Emerging weapons like LOCAAS and Damocles may serve as technology demonstrators and benefactors of concept**

**Possible applicability to some UAV applications**

**Figure 5.2—Conclusions Regarding Cooperative Weapon System Concept**

Our assessment illustrated some attractive potential benefits—robustness, adaptivity, enhanced effectiveness—from the integration of group behavior logic, communications among weapons, and the exploitation of new robotics architectures. For the most part, the weapon concept we explored draws on technologies that already exist or are in development either in the military or commercial arena, although clearly the elements must be integrated as a working system to demonstrate the concept’s viability.

Emerging weapons could provide a platform for demonstrating some of those technologies before they are integrated collectively into an all-new weapon system. In addition, the emerging weapons could realize some near-term effectiveness benefits from the addition of such technologies as communications.

Looking beyond expendable weapons, some of the behavioral notions embodied in this concept might find applicability in governing the behavior of groups of UAVs performing various military missions that

might otherwise place large demands on ground controllers. As in the case of weapon applications, greater reliance on autonomous system operation will introduce new operational considerations that will have to be dealt with before such systems can be integrated with confidence into existing forces.

**Consider combining communications with swarming behavior in the Air Force's High Leverage Munition-Anti-Materiel Submunition program**

- Demonstrate proof of concept with millimeter-wave communications package
- Pursue IR for operational system

**Examine commercial communications protocols for military applications**

**Assess robustness of swarming algorithms in the face of countermeasures**

**Figure 5.3—Possible Next Steps in Evolution of Weapons Using Cooperative Behavior**

Emerging munitions RDT&E programs can provide a vehicle for advancing weapons using cooperative behavior. The Air Force's roadmap for mobile target/standoff weapons includes a High Leverage Munition–Anti-Materiel Submunition (HLM-AMS) program that has several potential weapon candidates, including the Low Cost Autonomous Attack System or LOCAAS, the Army's Brilliant Anti-Armor Technology (BAT), and the Damocles concept. We believe communications and cooperative behavior logic that leads to swarming should be considered as candidates for inclusion during the evolution of this program.

Millimeter-wave communications would be suitable for initial evaluations, although our technical assessment suggests that ultimately an IR communications package might offer greater robustness to enemy jamming. The suitability of existing commercial communications protocols will need to be explored, as will the robustness of the

swarming algorithms to countermeasures that a determined enemy might develop.

Taking these steps should provide greater insights about the ultimate potential of weapons that use cooperative behavior logic and provide a better foundation for making future RDT&E investment decisions.

## Appendix

# MADAM MODEL DESCRIPTION<sup>1</sup>

MADAM, Model to Assess Damage to Armor with Munitions, was used to evaluate the addition of communications to developmental weapon concepts. The communications logic was added to the Damocles weapon to observe the impact on weapon effectiveness of better knowledge of weapon commitments to targets.

MADAM is a Monte Carlo, many-on-many weapons-effectiveness model written in FORTRAN. It is designed to assess the effectiveness of multiple attacks against complex arrays of ground targets at an aggregated level. It is not an engineering-level model, i.e., weapon-target interactions are based on user inputs of the probabilities of target acquisition and kill.

MADAM has principally been used to evaluate Army and Air Force attacks against various arrays of ground vehicles using “smart” submunitions as well as various conventional cluster munitions. MADAM exists as a standalone model and also has been integrated into the JANUS ground combat simulation at RAND.

The basic situations that can be modeled involve attacks by one or more aircraft or missiles that each dispense clusters of either “smart” or unguided conventional submunitions against collections of vehicles on the ground. For a given case, all attackers are of the same type, but they can be directed to attack the target array at multiple aim points from various headings. All attacks occur, effectively, at the same time, except that targets killed by one attacker cannot be killed again by another.

## TARGETS

- Multiple types of target vehicles may be specified.
- Target locations may be specified or automatically (1) spaced along a line, or arrayed (2) uniformly in a rectangle, or (3) at random in a rectangle, or (4) at random in an ellipse.
- Targets in columns may have a bend in the middle of the line.

---

<sup>1</sup>This appendix is abstracted from material originally prepared by Don Emerson.



- Several identical march units may be in columns, separated as specified.
- Targets do not move, but the effects of target location errors resulting from target movement may be approximated. An AMSAA formulation of the target-location bias-error from the GAMES II model is used.
- Target types can be ordered randomly or in a specified sequence.

### **DELIVERY VEHICLES (attackers)**

- All attackers (aircraft or missiles) are of the same type for a particular case.
- Attackers can carry a variety of munition types.
- Multiple aim points may be specified; a specific heading may be specified for the attackers directed at each aim point.
- A different number of attackers may be salvoed at each aim point.
- All attackers in a trial may be affected by a sample from random-bias error distributions.
- Errors induced by imprecision in measuring target location and in predicting future target position may also be represented. The samples of these random-bias errors are added to the other random-bias errors and affect all attackers equally.
- Each attacker is affected by its reliability, and its location is affected by heading errors and errors in range and deflection.

### **MUNITIONS**

- Unguided or smart submunitions are allowed.
- Sizes and shapes of search patterns used by each smart submunition type can be specified.
- Submunition reliability, acquisition, and kill probabilities can be specified.
- Other weapon-specific characteristics are incorporated through program coding or user inputs.

## **OUTPUTS**

Model outputs include

- The average number of targets of each type that are acquired and those that are killed.
- The number of targets of each type that sustain one to five killing hits.
- The number of false and dead targets that are acquired.
- The total number of targets that are acquired and that are killed.
- Sample statistics for several elements of the delivery errors are available.

## BIBLIOGRAPHY

Brooks, Rodney, "New Approaches to Robotics," *Science*, Sept. 13, 1991, p. 1227.

Corley, John, *Energetic Materials Research at WL/MN, Enhancing Lethality of Next Generation Ordnance Packages*, briefing to Air Force Scientific Advisory Board, 8 February 1996.

*Damocles—Autonomous Intelligent Submunition*, briefing presented to Col William Ervin, by Textron Defense Systems, Wilmington, Mass., 5 November 1993.

Grant, Gary, Dean Risseeuw, Dick McConville, *Damocles, Smart Munitions Study Data Sheets*, Textron Defense Systems, 24 February 1995.

Jacques, Major Dave, *Low Cost Autonomous Attack System, LOCAAS*, Wright Laboratory, Armament Directorate, 1997.

Levy, Stephen, *Artificial Life: The Quest for a New Creation*, Pantheon, New York, 1992.

"Miniature Jet Engines Spawn Multiple Applications," *Jane's International Defense Review*, April 1996, pp. 15, 16.

Mundelein, Lt Col Ted, Jr., *Miniaturized Munition Technology Demonstration (Small Smart Bomb Integration Concept)*, briefing to Air Force Scientific Advisory Board, 8 February 1996.

Prigogine, Ilya, and Isabelle Stengers, *Order Out of Chaos: Man's New Dialogue with Nature*, Bantam Books, New York, 1984.

Resnick, Mitchel, *Turtles, Termites, and Traffic Jams: Explorations in Massively Parallel Microworlds*, MIT Press, Cambridge, Massachusetts, 1994.

*Swarm Simulation*, <http://www.santafe.edu/projects/swarm/>.

Thro, Ellen, *Artificial Life Explorer's Kit*, Sams Publishing, Carmel, IN, 1993.

Tower, Michael, *Powered Low Cost Autonomous Attack System (LOCAAS)*, Lockheed Martin Vought Systems, August 1996.

Welle, Al, *Hard Target Penetrators*, briefing to Air Force Scientific Advisory Board, 8 February 1996.